

STATE OF NORTH CAROLINA
DEPARTMENT OF TRANSPORTATION
HIGHWAY DIVISION 14

ID/IQ PROPOSAL

DATE AND TIME OF BID OPENING: JUNE 23, 2026 AT 2:00 PM

CONTRACT ID: DN12225454

WBS ELEMENT NO.: GMR14.HAY.1P, GMR14.HAY.2P

FEDERAL AID NO.: STATE FUNDED

COUNTY: HAYWOOD

TIP NO.: N/A

MILES: VARIES

ROUTE NO.: I-40

**LOCATION: HAYWOOD COUNTY MASS CONCRETE ARCH TUNNELS:
#0104, I-40 EAST BOUND LANE, MP 8.28
#0015, I-40 EAST BOUND LANE, MP 4.12
#0017, I-40 WEST BOUND LANE, MP 32.53**

TYPE OF WORK: ID-IQ ON-CALL TUNNEL LIGHTING SERVICES

NOTICE:

ALL BIDDERS SHALL COMPLY WITH ALL APPLICABLE LAWS REGULATING THE PRACTICE OF GENERAL CONTRACTING AS CONTAINED IN CHAPTER 87 OF THE GENERAL STATUTES OF NORTH CAROLINA WHICH REQUIRES THE BIDDER TO BE LICENSED BY THE N.C. LICENSING BOARD FOR CONTRACTORS WHEN BIDDING ON ANY NON-FEDERAL AID PROJECT WHERE THE BID IS \$40,000 OR MORE, EXCEPT FOR CERTAIN SPECIALTY WORK AS DETERMINED BY THE LICENSING BOARD. BIDDERS SHALL ALSO COMPLY WITH ALL OTHER APPLICABLE LAWS REGULATING THE PRACTICES OF ELECTRICAL, PLUMBING, HEATING AND AIR CONDITIONING AND REFRIGERATION CONTRACTING AS CONTAINED IN CHAPTER 87 OF THE GENERAL STATUTES OF NORTH CAROLINA. NOTWITHSTANDING THESE LIMITATIONS ON BIDDING, THE BIDDER WHO IS AWARDED ANY FEDERAL - AID FUNDED PROJECT SHALL COMPLY WITH CHAPTER 87 OF THE GENERAL STATUTES OF NORTH CAROLINA FOR LICENSING REQUIREMENTS WITHIN 60 CALENDAR DAYS OF BID OPENING.

THIS IS A ROADWAY PROJECT.

BID BOND IS NOT REQUIRED.

NAME OF BIDDER

ADDRESS OF BIDDER

**PROPOSAL FOR THE CONSTRUCTION OF
 CONTRACT No. DN12225454 IN Haywood County, NORTH CAROLINA
 DEPARTMENT OF TRANSPORTATION,
 RALEIGH, NORTH CAROLINA**

The Bidder has carefully examined the location of the proposed work to be known as Contract No. DN12225454; has carefully examined the plans and specifications, which are acknowledged to be part of the proposal, the special provisions, the proposal, the form of contract; and thoroughly understands the stipulations, requirements and provisions. The undersigned bidder agrees to be bound upon his execution of the bid and subsequent award to him by the Department of Transportation in accordance with this proposal. Payment and performance bonds are not required on this project. The undersigned Bidder further agrees to provide all necessary machinery, tools, labor, and other means of construction; and to do all the work and to furnish all materials, except as otherwise noted, necessary to perform and complete the said contract in accordance with the *2024 Standard Specifications for Roads and Structures* by the dates(s) specified in the Project Special Provisions and in accordance with the requirements of the Engineer, and at the unit or lump sum prices, as the case may be, for the various items given on the sheets contained herein.

The Bidder shall provide and furnish all the materials, machinery, implements, appliances and tools, and perform the work and required labor to construct and complete Contract No. DN12225454 in Haywood County, for the unit or lump sum prices, as the case may be, bid by the Bidder in his bid and according to the proposal, plans, and specifications prepared by said Department, which proposal, plans, and specifications show the details covering this project, and hereby become a part of this contract.

The published volume entitled *North Carolina Department of Transportation, Raleigh, Standard Specifications for Roads and Structures, January 2024* with all amendments and supplements thereto, is by reference incorporated into and made a part of this contract; that, except as herein modified, all the construction and work included in this contract is to be done in accordance with the specifications contained in said volume, and amendments and supplements thereto, under the direction of the Engineer.

If the proposal is accepted and the award is made, the contract is valid only when signed either by the Contract Officer or such other person as may be designated by the Secretary to sign for the Department of Transportation. The conditions and provisions herein cannot be changed except over the signature of the said Contract Officer or Division Engineer.

The quantities shown in the itemized proposal for the project are considered to be approximate only and are given as the basis for comparison of bids. The Department of Transportation may increase or decrease the quantity of any item or portion of the work as may be deemed necessary or expedient.

An increase or decrease in the quantity of an item will not be regarded as sufficient ground for an increase or decrease in the unit prices, nor in the time allowed for the completion of the work, except as provided for the contract.

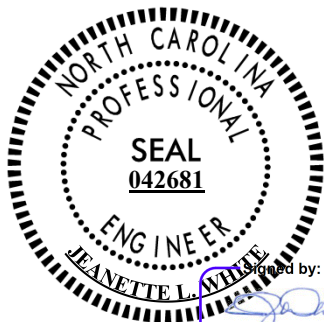

Prepared by:

 29BD93927CF24F6...
 05/27/2026

TABLE OF CONTENTS

**COVER SHEET
PROPOSAL SHEET**

PROJECT SPECIAL PROVISIONS

MANDATORY PRE-BID CONFERENCE (Prequalifying To Bid): G-1
 INTERESTED PARTIES LIST NOT REQUIRED: G-2
 HAUL ROADS: G-2
 CONTRACT TIME FOR ID/IQ: G-2
 NON-EXCLUSIVE CONTRACT: G-2
 WORK ORDER ASSIGNMENT (MULTIPLE AWARDS) FOR ID/IQ: G-3
 BONDING REQUIREMENTS FOR ID/IQ: G-3
 MOBILIZATION AND LIQUIDATED DAMAGES FOR ID/IQ: G-4
 EMERGENCY MOBILIZATION FOR ID/IQ: G-5
 RENEWAL OF CONTRACT (CPI PRICE ADJUSTMENT) FOR ID/IQ: G-5
 DISPUTE RESOLUTION PROCESS FOR ID/IQ: G-5
 INTERMEDIATE CONTRACT TIME NUMBER 1 AND LIQUIDATED DAMAGES: G-6
 NO MAJOR CONTRACT ITEMS: G-8
 NO SPECIALTY ITEMS: G-8
 SCHEDULE OF ESTIMATED COMPLETION PROGRESS: G-8
 MINORITY BUSINESS ENTERPRISE AND WOMEN BUSINESS ENTERPRISE
 (DIVISIONS): G-8
 MULTI-YEAR MAINTENANCE CONTRACTS (ID/IQ): G-24
 RESTRICTIONS ON ITS EQUIPMENT AND SERVICES: G-24
 USE OF UNMANNED AIRCRAFT SYSTEM (UAS): G-24
 EQUIPMENT IDLING GUIDELINES: G-24
 OUTSOURCING OUTSIDE THE USA: G-25
 NOTES TO CONTRACTOR: G-25

ROADWAYR-1

STANDARD SPECIAL PROVISIONS

AVAILABILITY OF FUNDS – TERMINATION OF CONTRACTSSSP-1
 ERRATASSP-2
 PLANT AND PEST QUARANTINESSSP-5
 MINIMUM WAGESSSP-6
 TITLE VI AND NONDISCRIMINATION:SSP-7
 ON-THE-JOB TRAININGSSP-16

UNIT PROJECT SPECIAL PROVISIONS

TRAFFIC CONTROL TC-1
 LIGHTING LT-1
 EROSION CONTROL EC-1

SIGNATURE SHEETS AND FORMS S-1
BID/PAY ITEM SHEETS T-1
DOT EXECUTION SHEET U-1

INSTRUCTIONS TO BIDDERS

PLEASE READ ALL INSTRUCTIONS CAREFULLY BEFORE PREPARING AND SUBMITTING YOUR BID.

All bids shall be prepared and submitted in accordance with the following requirements. Failure to comply with any requirement may cause the bid to be considered irregular and may be grounds for rejection of the bid.

TRADITIONAL PAPER BIDS:

1. Download the entire proposal from the Connect NCDOT website and return the entire proposal with your bid.
2. In accordance with Article 102-3 of the *Standard Specifications*, registration on the Interested Parties List is required unless SP1 G02 Interested Parties List Not Required provision is included in the proposal.
3. All entries on the itemized proposal sheet (bid form) shall be written in ink or typed.
4. The Bidder shall submit a unit price for every item on the itemized proposal sheet. The unit prices for the various contract items shall be written in figures. Unit prices shall be rounded off by the Bidder to contain no more than FOUR decimal places.
5. An amount bid shall be entered on the itemized proposal sheet for every item. The amount bid for each item shall be determined by multiplying each unit bid by the quantity for that item, and shall be written in figures in the "Amount" column of the form.
6. The total amount bid shall be written in figures in the proper place on the bid form. The total amount bid shall be determined by adding the amounts bid for each item.
7. Changes to any entry shall be made by marking through the entry in ink and making the correct entry adjacent thereto in ink. A representative of the Bidder shall initial the change in ink. Do not use correction fluid, correction tape or similar product to make corrections.
8. The bid shall be properly executed on the included **Execution of Bid – Non-collusion, Debarment and Gift Ban Certification** form. All bids shall show the following information:
 - a. Name of corporation, partnership, Limited Liability Company, joint venture, individual or firm, submitting bid.
Corporations that have a corporate seal shall include it on the bid, otherwise write your corporations name in the seal location.
 - b. Name of individual or representative submitting bid and position or title held on behalf of the bidder.
 - c. Name, signature, and position or title of witness.
9. The bid shall not contain any unauthorized additions, deletions, or conditional bids.
10. The Bidder shall not add any provision reserving the right to accept or reject an award, or to enter into a contract pursuant to an award.
11. **THE PROPOSAL WITH THE ITEMIZED PROPOSAL SHEET ATTACHED SHALL BE PLACED IN A SEALED ENVELOPE AND SHALL BE DELIVERED TO AND RECEIVED IN THE NCDOT DIVISION OFFICE, LOCATED AT 253 Webster Road Sylva, NC 28779, BY 2:00 PM ON, June 23, 2026.**
12. The sealed bid must display the following statement on the front of the sealed envelope:

**QUOTATION FOR – CONTRACT ID DN12225454 – ID-IQ ON-CALL TUNNEL LIGHTING
SERVICES AT HAYWOOD COUNTY MASS CONCRETE ARCH TUNNELS:**

#0104, I-40 EAST BOUND LANE, MP 8.28

#0015, I-40 EAST BOUND LANE, MP 4.12

#0017, I-40 WEST BOUND LANE, MP 32.53 TO BE OPENED AT 2:00 PM ON, June 23, 2026.

As well as the following information:

- a. Name of corporation, partnership, Limited Liability Company, joint venture, individual or firm, submitting bid.
- b. Name of individual or representative submitting bid and position or title held on behalf of the bidder.
- c. Address of corporation, partnership, Limited Liability Company, joint venture, individual or firm, submitting bid.

- d. SAP Vendor Number of corporation, partnership, Limited Liability Company, joint venture, individual or firm, submitting bid.
 - e. Contractor License Number, if available, of corporation, partnership, Limited Liability Company, joint venture, individual or firm, submitting bid.
13. If delivered by mail, the sealed envelope shall be placed in another sealed envelope and the outer envelope shall be addressed as follows:

**N. C. DEPARTMENT OF TRANSPORTATION
DIVISION OF HIGHWAYS, DIVISION 14
ATTN: Jeffrey E. Alspaugh, EI
253 Webster Road
Sylva, NC 28779**

14. Questions should be emailed 7 calendar days prior to the bid opening to **Jeffrey E. Alspaugh, EI** at **d14contracts@ncdot.gov**. Contact with any other NCDOT personnel concerning this project is strictly prohibited, unless otherwise noted, and may result in bids being considered non-responsive.

PROJECT SPECIAL PROVISIONS**GENERAL****MANDATORY PRE-BID CONFERENCE (Prequalifying To Bid):**

(7-18-06) (Rev. 3-25-13)

SPD 1-310

In order for all prospective bidders to have an extensive knowledge of the project, all prospective bidders shall attend a mandatory pre-bid conference on **Monday, June 15, 2026, at 12:00 PM.**

Location: **NCDOT Division 14 Office
253 Webster Rd
Sylva NC 28779**

Point of Contact: **Spencer McDonald
(828) 488-0902**

The pre-bid conference will include a thorough discussion of the plans, contract pay items, special provisions, etc.

Only bidders who have attended and properly registered at the above scheduled pre-bid conference and who have met all other prequalification requirements will be considered prequalified to bid on this project. A bid received from a bidder who has not attended and properly registered at the above scheduled pre-bid conference will not be accepted and considered for award.

Attendance at the pre-bid conference will not meet the requirements of proper registration unless the individual attending has registered at the pre-bid conference in accordance with the following:

- (A) The individual has signed his name on the official roster prior to the above noted time for the beginning of the conference.
- (B) The individual has written in the name and address of the company he or she represents.
- (C) Only one company has been shown as being represented by the individual attending.
- (D) The individual attending is an officer or permanent employee of the company they are representing.

Any individual arriving after the official roster has been received by the Engineer will not be eligible to bid. Attendance at any prior pre-bid conference will not meet the requirement of this provision.

INTERESTED PARTIES LIST NOT REQUIRED:

(6-21-22)(Rev. 2-20-24)

102

SP1 G02

Revise the *Standard Specifications* as follows:

The *Interested Parties List* sign up process is not applicable to this contract.

Page 1-13, Article 102-3 PROPOSALS AND INTERESTED PARTIES LIST, lines 12-15, delete the first paragraph.

Page 1-14, Article 102-8 PREPARATION AND SUBMISSION OF BIDS, lines 43-44, delete the first sentence of the first paragraph.

HAUL ROADS:

(7-16-24)

105

SP1 G04

Revise the *Standard Specifications* as follows:

Page 1-45, Article 105-15 RESTRICTION OF LOAD LIMITS, line 31, add the following after second sentence of the second paragraph:

At least 30 days prior to use, the Contractor shall notify the Engineer of any public road proposed for use as a haul road for the project.

CONTRACT TIME FOR ID/IQ:

(2-15-22)(Rev. 4-15-25)

108

SP1 G11

The date of availability for this contract is **July 20, 2026.**

The completion date for this contract is **July 19, 2027.**

Except where otherwise provided by the contract, observation periods required by the contract will not be a part of the work to be completed by the completion date and/or intermediate contract times stated in the contract. The acceptable completion of the observation periods that extend beyond the final completion date shall be a part of the work covered by the performance and payment bonds.

Work shall be accomplished in a continuous manner once the contractor begins.

The liquidated damages for this contract will be assessed per the Mobilization and Liquidated Damages for ID/IQ provision located elsewhere in this contract.

NON-EXCLUSIVE CONTRACT:

(6-1-15)

SPD 01-750

The Department may, as it deems to be in the best interest of the state and the Department of Transportation, execute more than one contract based on this proposal. The Contractor(s) understands and agrees, by signature on the Purchase Order Contract Bid Proposal, that this agreement does not constitute an exclusive contract. If awarded, the contracts will be executed with the lowest responsible bidders. The Department of Transportation reserves the right to make

multiple awards for the services provided by this contract. Furthermore, the Department reserves the right to reject all bids received.

WORK ORDER ASSIGNMENT (MULTIPLE AWARDS) FOR ID/IQ:

(2-15-22)(Rev. 4-19-22)

SPD 01-800B

Work orders will be assigned based on the lowest work order cost for the line items and estimated quantities necessary to complete the work order. Unit prices from each awarded contractor's bid will be used to determine the lowest cost for each work order. The assigned Contractor shall respond to the work order assignment with the anticipated start date, within three working days of notification unless noted otherwise. Failure on the part of the Contractor to reply within the specified time frame may be received as a rejection of the work order. If the Contractor with the lowest work order cost cannot complete the work within the time specified in the assignment, the Engineer may contact the Contractor with the next lowest work order cost. If that Contractor can complete the work within the time specified in the assignment, then the work order will be assigned to that contractor. If not, assignment of work order will continue in order of work order cost until all awarded Contractors have had a chance to accept the terms of the assignment.

For federal ID/IQ contracts, all work orders will be assigned via the Work Order Assignment form (Form IDIQ-1MA), and the Contractor is required to formally respond in writing for federal work orders within three working days, unless noted otherwise. The Work Order Assignment form will also be used for any state ID/IQ contract in which the estimated work order cost meets the threshold for Performance and Payment Bonds in accordance with the Bonding Requirements for ID/IQ provision found elsewhere in this contract. For state ID/IQ contracts in which the work order assignment doesn't meet the threshold for bonds, the Department has the option to use the Work Order Assignment Form or other methods for work order assignments as agreed upon by the Engineer and Contractor.

The Contractor shall be required to prosecute the work in a continuous and uninterrupted manner from the time they begin the work until completion and final acceptance of the work order. Multiple failures of the Contractor to mobilize and begin work on the work order within the agreed upon time frame or failure to complete the work within the given time frame may result in the Contractor being excluded from future work on this contract in accordance with the *Standard Specifications*.

BONDING REQUIREMENTS FOR ID/IQ:

(2-15-22)

SPD 01-810

For purposes of this ID/IQ contract, the following definitions apply:

Project Agreement: A transportation improvement with a defined scope of work; a written agreement between NCDOT and the Federal Government defining the extent of construction work to be undertaken in accordance with the submitted plans, specifications and estimates. Execution of the agreement prompts the authorization to proceed (construction funding).

Project: An undertaking issued to a contractor through a Work Order Assignment. The construction under a Project Agreement may be accomplished by one or more work order assignments, from one or more ID/IQ contracts. Note that for ID/IQ contracts this definition supersedes the definition in the Standard Specifications.

Award: The issuance of a signed Work Order Assignment by NCDOT shall constitute the notice of award of a project.

In accordance with North Carolina General Statute 44A-26, bonds are required on contracts awarded for any one project that exceeds \$500,000. Beyond statutory requirements, NCDOT policy requires payment and performance bonds on all projects where the engineer's estimate is \$450,000 or greater, all Asphalt Surface Treatment projects, and projects containing the 12-month guarantee provision. The limit for waiving bonds for all bridge replacement and major bridge rehabilitation projects (latex overlays, etc.) is \$300,000 based on the engineer's estimate. The decision of bonding of a work order assignment below the dollar amounts listed shall be at the discretion of the Division's evaluation of the risks associated with the project.

The need for contract payment and performance bonds will be determined at the Work Order Assignment level. The Work Order Assignment will notify the Contractor of an award of a project and if required, to provide contract payment and performance bonds per Article 103-7 of the *Standard Specifications*. The Work Order Assignment replaces the Notification of Award Letter mentioned in Article 103-4(A) of the *Standard Specifications*.

MOBILIZATION AND LIQUIDATED DAMAGES FOR ID/IQ:

(2-15-22)

SPD 01-820

The Contractor shall mobilize to each location he is required to perform work. There will be no direct pay for Mobilization as it will be incidental to the other bid items. The only exception is if there is an Emergency Mobilization provision within the contract.

The Contractor will be provided a Work Order Assignment for each project with location(s), estimated quantities, and liquidated damages unless waived by the Engineer. Notification will be verbal followed by a faxed or emailed signed Work Order Assignment. There will be no minimum quantities for any line item associated with a particular mobilization. The Contractor shall complete the work identified on each Work Order Assignment.

The Contractor shall mobilize and complete the work within the time specified on the Work Order Assignment. Failure to complete the work by the completion date may result in the application of liquidated damages. Liquidated damage amounts will be based on the work order estimate and the liquidated damage table below.

Work Order Value	Liquidated Damages (per calendar day)
\$0 - \$100K	\$100.00
\$100K - \$200K	\$250.00
\$200K - \$300K	\$500.00
\$300K - \$500K	\$600.00
\$500K - \$1M	\$700.00
\$1M - \$2M	\$850.00

EMERGENCY MOBILIZATION FOR ID/IQ:

(2-15-22)

SPD 01-830

The Contractor shall arrive on site within **Forty Eight (48)** hours of notification. Compensation will be in addition to the specific line items in the contract. *Emergency Mobilization* will be paid for at the contract unit price per each. Failure to respond within the time frame will result in nonpayment of this item.

Payment will be made under:

Pay Item	Pay Unit
Emergency Mobilization	Each

RENEWAL OF CONTRACT (CPI PRICE ADJUSTMENT) FOR ID/IQ:

(2-15-22)(Rev. 9-19-23)

SPD 01-840

The Contractor shall submit a bid for one year. At the option of the Department, this contract may be extended for **Two (2)** additional periods of one year each (maximum (3) three years total). Each year shall have a limit of **Five Million Dollars (\$5,000,000.00)**.

The compensation payable to the contractor shall be fixed for the first twelve months of this contract. However, upon an application of renewal of the contract, or thirty days prior to the end of each contract period, the renewal contract may be adjusted to reflect the adjustment in the Consumer Price Index over the latest twelve month period as published by the US Bureau of Labor and Statistics at <http://www.bls.gov/cpi> to be applied to new work order assignments. The Consumer Price Index for All Urban Consumers (CPI-U), US City Average, All Items, 1982-84=100, not seasonally adjusted will be used. If the amount of the requested adjustment is more than ten percent, the Department of Transportation reserves the right to cancel this contract.

CPI adjustment values can be determined using the calculator on the NCDOT Construction website.

This price escalation method will not be applied to items of work that are separately covered under commodity price escalation clauses. No other changes in the terms, conditions, etc. of this contract will be made when an extension to the contract is implemented. The Engineer will notify the Contractor in writing by **60** if the contract may be extended. The Contractor must notify the Engineer in writing by **30** of his acceptance or rejection of this offer. Failure on the part of the Contractor to reply will be received as a rejection of contract extension.

DISPUTE RESOLUTION PROCESS FOR ID/IQ:

(2-15-22)(Rev. 1-16-24)

SPD 01-850

If a question should arise on the contract or assignment of a work order, the contractor should notify the Engineer noted on the assignment documentation or the Division Engineer within 48 hours after the scheduled time of bid opening or work order assignment. The following should be included in the notification if applicable:

- (A) the contract for which bids were solicited;
- (B) the particular law, regulation, or contract specification violated;
- (C) a detailed description of the alleged violation; and
- (D) any other information deemed to be relevant.

Once the initial evaluation has been completed, the contractor may be asked to attend a meeting for further discussion and clarification.

Once a determination has been made, the contractor will be notified of the decision by the Division Engineer. If the decision does not meet the satisfaction of the contractor, they have 24 hours from the Division Engineer’s notification to elevate the dispute to the Chief Engineer. The Chief Engineer will make the final decision and will not be subject to further review by NCDOT.

INTERMEDIATE CONTRACT TIME NUMBER 1 AND LIQUIDATED DAMAGES:

(2-20-07)

108

SP1 G14 A

The Contractor shall complete the required work of installing, maintaining, and removing the traffic control devices for lane closures and restoring traffic to a multi-lane two-way traffic pattern.

The Contractor shall not close or narrow a lane of traffic on **I-40 from Exit 27 (US 74) to Buncombe County Line in Haywood County** during the following time restrictions:

DAY AND TIME RESTRICTIONS

Dates	Monday through Thursday	Friday	Saturday	Sunday
October 1, 2026 through November 2, 2026 (Leaf Season)	from 6:00A.M. to 7:00 P.M	from 6:00A.M. to 9:00 P.M	from 9:00A.M. to 9:00 P.M	from Noon. to 8:00 P.M
May 21, 2026 through September 8, 2026 (Summer)	from 6:00A.M. to 7:00 P.M	from 6:00A.M. to 9:00 P.M	from 9:00A.M. to 9:00 P.M	from Noon. to 8:00 P.M
November 20, 2026 through January 6, 2027 (Christmas Retail)	from 6:00A.M. to 9:00 P.M	All Times	All Times	All Times
December 16, 2026 through January 6, 2027 (Christmas)	All Times	All Times	All Times	All Times
March 25, 2027 through March 29, 2027 (Easter)	All Times	All Times	All Times	All Times
May 28, 2027 through June 1, 2027 (Memorial Day)	All Times	All Times	All Times	All Times
12:00 Noon July 2, 2026 through 8:00 AM July 7, 2026 (Independence Day)	All Times	All Times	All Times	All Times

August 27, 2026 through September 1, 2026 (Labor Day)	All Times	All Times	All Times	All Times
November 24, 2026 through November 30, 2026 (Thanksgiving)	All Times	All Times	All Times	All Times

In addition, the Contractor shall not close or narrow a lane of traffic on Non-Freeway Routes, detain and/or alter the traffic flow on or during holidays, holiday weekends, special events, or any other time when traffic is unusually heavy, including the following schedules:

HOLIDAY AND HOLIDAY WEEKEND LANE CLOSURE RESTRICTIONS

1. For **unexpected occurrence** that creates unusually high traffic volumes, as directed by the Engineer.
2. For **New Year's Day**, between the hours of 4:00 p.m. December 31st and 7:00 a.m. January 2nd. If New Year's Day is on a Friday, Saturday, Sunday or Monday, then until 7:00 a.m. the following Tuesday.
3. For **Easter**, between the hours of 4:00 p.m. Thursday and 7:00 a.m. Monday.
4. For **Memorial Day**, between the hours of 4:00 p.m. Friday and 7:00 a.m. Tuesday.
5. For **Independence Day**, between the hours of 4:00 p.m. the day before Independence Day and 7:00 a.m. the day after Independence Day.

If **Independence Day** is on a Friday, Saturday, Sunday or Monday, then between the hours of 4:00 p.m. the Thursday before Independence Day and 7:00 a.m. the Tuesday after Independence Day.

6. For **Labor Day**, between the hours of 4:00 p.m. Friday and 7:00 a.m. Tuesday.
7. For **Thanksgiving Day**, between the hours of 4:00 p.m. Tuesday and 7:00 a.m. Monday.
8. For **Christmas**, between the hours of 4:00 p.m. the Friday before the week of Christmas Day and 7:00 a.m. the following Tuesday after the week of Christmas Day.

Holidays and holiday weekends shall include New Year's, Easter, Memorial Day, Independence Day, Labor Day, Thanksgiving, and Christmas. The Contractor shall schedule his work so that lane closures are not required during these periods, unless otherwise directed by the Engineer.

The time of availability for this intermediate contract work shall be the time the Contractor begins to install all traffic control devices for lane closures according to the time restrictions listed herein.

The completion time for this intermediate contract work shall be the time the Contractor is required to complete the removal of all traffic control devices for lane closures according to the time restrictions stated herein and place traffic in a normal traffic pattern.

The liquidated damages are **Two Hundred Fifty Dollars (\$250.00)** per hour.

NO MAJOR CONTRACT ITEMS:

(2-19-02)(Rev. 8-21-07)

104

SP1 G31

None of the items included in this contract will be major items.

NO SPECIALTY ITEMS:

(7-1-95)(Rev. 1-16-24)

108-6

SP1 G34

None of the items included in this contract will be specialty items (see Article 108-6 of the *Standard Specifications*).

SCHEDULE OF ESTIMATED COMPLETION PROGRESS:

(7-15-08)(Rev. 6-16-26)

108-2

SP1 G58

The Contractor's attention is directed to the Standard Special Provision entitled *Availability of Funds Termination of Contracts* included elsewhere in this proposal. The Department of Transportation's schedule of estimated completion progress for this project as required by that Standard Special Provision is as follows:

<u>Fiscal Year</u>	<u>Progress (% of Dollar Value)</u>
2027 (7/01/26 - 6/30/27)	95% of Total Amount Bid
2028 (7/01/27 - 6/30/28)	5% of Total Amount Bid

The Contractor shall also furnish his own progress schedule in accordance with Article 108-2 of the *Standard Specifications*. Any acceleration of the progress as shown by the Contractor's progress schedule over the progress as shown above shall be subject to the approval of the Engineer.

MINORITY BUSINESS ENTERPRISE AND WOMEN BUSINESS ENTERPRISE (DIVISIONS):

(10-16-07)(Rev. 10-21-25)

102-15(J)

SP1 G67

Description

The purpose of this Special Provision is to carry out the North Carolina Department of Transportation's policy of ensuring nondiscrimination in the award and administration of contracts financed in whole or in part with State funds.

Definitions

Additional MBE/WBE Subcontractors - Any MBE/WBE submitted at the time of bid that will not be used to meet the Combined MBE/WBE goal. No submittal of a Letter of Intent is required.

Combined MBE/WBE Goal: A portion of the total contract, expressed as a percentage that is to be performed by committed MBE/WBE subcontractors.

Committed MBE/WBE Subcontractor - Any MBE/WBE submitted at the time of bid that is being used to meet the Combined MBE / WBE goal by submission of a Letter of Intent. Or any MBE or WBE used as a replacement for a previously committed MBE or WBE firm.

Contract Goal Requirement - The approved participation at time of award, but not greater than the advertised Combined MBE/WBE contract goal.

Goal Confirmation Letter - Written documentation from the Department to the bidder confirming the Contractor's approved, committed participation along with a listing of the committed MBE and WBE firms.

Manufacturer - A firm that owns (or leases) and operates or maintains a factory or establishment that produces on the premises, the materials or supplies obtained by the Contractor. A firm that makes minor modifications to the materials, supplies, articles, or equipment is not a manufacturer.

MBE Participation (Anticipated) - A portion of the total contract, expressed as a percentage that is anticipated to be performed by committed MBE subcontractor(s).

Minority Business Enterprise (MBE) - A firm certified as a Disadvantaged Minority-Owned Business Enterprise through the North Carolina Unified Certification Program.

Regular Dealer - A firm that owns (or leases), and operates a store, warehouse, or other establishment in which the materials or supplies required for the performance of the contract are bought, kept in sufficient quantities, and regularly sold to the public in the usual course of business. A regular dealer engages in, as its principal business and in its own name, the purchase and sale or lease of the products in question. A regular dealer in such bulk items as steel, concrete or concrete products, gravel, stone, asphalt and petroleum products need not keep such products in stock, if it owns and operates distribution equipment for the products. Any supplement of regular dealers' own distribution equipment shall be by a long-term operating lease and not on an ad hoc or contract-by-contract basis.

Distributor – A firm that engages in the regular sale or lease of the items specified by the contract. A distributor assumes responsibility for the items it purchases once they leave the point of origin (e.g., a manufacturer's facility), making it liable for any loss or damage not covered by the carrier's insurance.

Replacement / Substitution – A full or partial reduction in the amount of work subcontracted to a committed (or an approved substitute) MBE/WBE firm.

North Carolina Unified Certification Program (NCUCP) - A program that provides comprehensive services and information to applicants for MBE/WBE certification. The MBE/WBE program follows the same regulations as the federal Disadvantaged Business Enterprise (DBE) program in accordance with 49 CFR Part 26.

United States Department of Transportation (USDOT) - Federal agency responsible for issuing regulations (49 CFR Part 26) and official guidance for the DBE program.

WBE Participation (Anticipated) - A portion of the total contract, expressed as a percentage that is anticipated to be performed by committed WBE subcontractor(s).

Women Business Enterprise (WBE) - A firm certified as a Disadvantaged Women-Owned Business Enterprise through the North Carolina Unified Certification Program.

Forms and Websites Referenced in this Provision

Payment Tracking System - On-line system in which the Contractor enters the payments made to MBE and WBE subcontractors who have performed work on the project.
<https://apps.dot.state.nc.us/Vendor/PaymentTracking/>

DBE-IS Subcontractor Payment Information - Form for reporting the payments made to all MBE/WBE firms working on the project. This form is for paper bid projects only.
<https://connect.ncdot.gov/business/Turnpike/Documents/Form%20DBE-IS%20Subcontractor%20Payment%20Information.pdf>

RF-1 MBE/WBE Replacement Request Form - Form for replacing a committed MBE or WBE.
<https://connect.ncdot.gov/projects/construction/Construction%20Forms/DBE%20MBE%20WBE%20Replacement%20Form%20and%20Instructions.pdf>

SAF Subcontract Approval Form - Form required for approval to sublet the contract.
<https://connect.ncdot.gov/projects/construction/Construction%20Forms/SAF%20Form%20-%20Subcontract%20Approval%20Form%20Revised%2004-19.xlsm>

JC-1 Joint Check Notification Form - Form and procedures for joint check notification. The form acts as a written joint check agreement among the parties providing full and prompt disclosure of the expected use of joint checks.
<http://connect.ncdot.gov/projects/construction/Construction%20Forms/Joint%20Check%20Notification%20Form.pdf>

Letter of Intent - Form signed by the Contractor and the MBE/WBE subcontractor, manufacturer or regular dealer that affirms that a portion of said contract is going to be performed by the signed MBE/WBE for the estimated amount (based on quantities and unit prices) listed at the time of bid.
<http://connect.ncdot.gov/letting/LetCentral/Letter%20of%20Intent%20to%20Perform%20as%20a%20Subcontractor.pdf>

Listing of MBE and WBE Subcontractors Form - Form for entering MBE/WBE subcontractors on a project that will meet the Combined MBE/WBE goal. This form is for paper bids only.

[http://connect.ncdot.gov/municipalities/Bid%20Proposals%20for%20LGA%20Content/09%20MBE-WBE%20Subcontractors%20\(State\).docx](http://connect.ncdot.gov/municipalities/Bid%20Proposals%20for%20LGA%20Content/09%20MBE-WBE%20Subcontractors%20(State).docx)

Subcontractor Quote Comparison Sheet - Spreadsheet for showing all subcontractor quotes in the work areas where MBEs and WBEs quoted on the project. This sheet is submitted with good faith effort packages.

<http://connect.ncdot.gov/business/SmallBusiness/Documents/DBE%20Subcontractor%20Quote%20Comparison%20Example.xls>

DBE Regular Dealer/Distributor Affirmation Form – Form is used to make a preliminary counting determination for each DBE listed as a regular dealer or distributor to assess its eligibility for 60 or 40 percent credit, respectively of the cost of materials or supplies based on its demonstrated capacity and intent to perform as a regular dealer or distributor, as defined in section 49 CFR 26.55 under the contract at issue. A Contractor will submit the completed form with the Letter of Intent. <https://connect.ncdot.gov/projects/construction/Construction%20Forms/DBE%20Regular%20Dealer-Distributor%20Affirmation%20Form%20-%20USDOT%202024.pdf>

Combined MBE/WBE Goal

There is NO MBE/WBE Goal for this project.

Directory of Transportation Firms (Directory)

Real-time information is available about firms doing business with the Department and firms that are certified through NCUCP in the Directory of Transportation Firms. Only firms identified in the Directory as MBE and WBE certified shall be used to meet the Combined MBE / WBE goal. The Directory can be found at the following link.

<https://www.ebs.nc.gov/VendorDirectory/default.html>

The listing of an individual firm in the directory shall not be construed as an endorsement of the firm's capability to perform certain work.

Listing of MBE/WBE Subcontractors

At the time of bid, bidders shall submit all MBE and WBE participation that they anticipate to use during the life of the contract. Only those identified to meet the Combined MBE/WBE goal will be considered committed, even though the listing shall include both committed MBE/WBE subcontractors and additional MBE/WBE subcontractors. Any additional MBE/WBE subcontractor participation above the goal will follow the banking guidelines found elsewhere in this provision. All other additional MBE/WBE subcontractor participation submitted at the time of bid will be used toward the Department's overall race-neutral goals. Only those firms with current MBE and WBE certification at the time of bid opening will be acceptable for listing in the bidder's submittal of MBE and WBE participation. The Contractor shall indicate the following required information:

(A) Electronic Bids

Bidders shall submit a listing of MBE and WBE participation in the appropriate section of the electronic submittal file.

- (1) Submit the names and addresses of MBE and WBE firms identified to participate in the contract. If the bidder uses the updated listing of MBE and WBE firms shown in the electronic submittal file, the bidder may use the dropdown menu to access the name and address of the firms.
- (2) Submit the contract line numbers of work to be performed by each MBE and WBE firm. When no figures or firms are entered, the bidder will be considered to have no MBE or WBE participation.
- (3) The bidder shall be responsible for ensuring that the MBE and WBE are certified at the time of bid by checking the Directory of Transportation Firms. If the firm is not certified at the time of the bid-letting, that MBE's or WBE's participation will not count towards achieving the Combined MBE/WBE goal.

(B) Paper Bids

- (1) *If the Combined MBE/ WBE goal is more than zero,*
 - (a) Bidders, at the time the bid proposal is submitted, shall submit a listing of MBE/WBE participation, including the names and addresses on *Listing of MBE and WBE Subcontractors* contained elsewhere in the contract documents in order for the bid to be considered responsive. Bidders shall indicate the total dollar value of the MBE and WBE participation for the contract.
 - (b) If bidders have no MBE or WBE participation, they shall indicate this on the *Listing of MBE and WBE Subcontractors* by entering the word "None" or the number "0." This form shall be completed in its entirety. **Blank forms will not be deemed to represent zero participation.** Bids submitted that do not have MBE and WBE participation indicated on the appropriate form will not be read publicly during the opening of bids. The Department will not consider these bids for award and the proposal will be rejected.
 - (c) The bidder shall be responsible for ensuring that the MBE/WBE is certified at the time of bid by checking the Directory of Transportation Firms. If the firm is not certified at the time of the bid-letting, that MBE's or WBE's participation will not count towards achieving the Combined MBE/WBE goal.
- (2) *If the Combined MBE/WBE Goal is zero,* entries on the *Listing of MBE and WBE Subcontractors* are not required for the zero goal, however any MBE or WBE

participation that is achieved during the project shall be reported in accordance with requirements contained elsewhere in the special provision.

MBE or WBE Prime Contractor

When a certified MBE or WBE firm bids on a contract that contains a Combined MBE/WBE Goal, the firm is responsible for meeting the goal or making good faith efforts to meet the goal, just like any other bidder. In most cases, a MBE or WBE bidder on a contract will meet the Combined MBE/WBE goal by virtue of the work it performs on the contract with its own forces. However, all the work that is performed by the MBE or WBE bidder and any other similarly certified subcontractors will count toward the goal. The MBE or WBE bidder shall list itself along with any MBE or WBE subcontractors, if any, in order to receive credit toward the goals.

MBE/WBE prime contractors shall also follow Sections A or B listed under *Listing of MBE/WBE Subcontractors* just as a non-MBE/WBE bidder would.

Written Documentation – Letter of Intent

The bidder shall submit written documentation for each MBE/WBE that will be used to meet the Combined MBE/WBE goal of the contract, indicating the bidder's commitment to use the MBE/WBE in the contract. This documentation shall be submitted on the Department's form titled *Letter of Intent*.

The documentation shall be received in the office of the Engineer no later than 2:00 p.m. of the fifth calendar day following opening of bids, unless the fifth day falls on Saturday, Sunday or an official state holiday. In that situation, it is due in the office of the Engineer no later than 10:00 a.m. on the next official state business day.

If the bidder fails to submit the Letter of Intent from each committed MBE and WBE to be used toward the Combined MBE/WBE goal, or if the form is incomplete (i.e. both signatures are not present), the MBE/WBE participation will not count toward meeting the Combined MBE/WBE goal. If the lack of this participation drops the commitment below the Combined MBE/WBE goal, the Contractor shall submit evidence of good faith efforts for the goal not met, completed in its entirety, to the Engineer no later than 2:00 p.m. of the eighth calendar day following opening of bids, unless the eighth day falls on Saturday, Sunday or an official state holiday. In that situation, it is due in the office of the Engineer no later than 10:00 a.m. on the next official state business day.

Banking MBE/WBE Credit

If the committed MBE/WBE participation submitted exceeds the algebraic sum of the Combined MBE/WBE goal by \$1,000 or more, the excess will be placed on deposit by the Department for future use by the bidder. Separate accounts will be maintained for MBE and WBE participation and these may accumulate for a period not to exceed 24 months.

When the apparent lowest responsive bidder fails to submit sufficient participation by MBE and WBE firms to meet the advertised goal, as part of the good faith effort, the Department will

consider allowing the bidder to withdraw funds to meet the Combined MBE/WBE goal as long as there are adequate funds available from the bidder's MBE and WBE bank accounts.

Submission of Good Faith Effort

If the bidder fails to meet or exceed the Combined MBE/WBE goal, the apparent lowest responsive bidder shall submit to the Department documentation of adequate good faith efforts made to reach that specific goal.

One complete set and **2** copies of this information shall be received in the office of the Engineer no later than 2:00 p.m. of the fifth calendar day following opening of bids, unless the fifth day falls on Saturday, Sunday or an official state holiday. In that situation, it is due in the office of the Engineer no later than 10:00 a.m. on the next official state business day.

Note: Where the information submitted includes repetitious solicitation letters, it will be acceptable to submit a representative letter along with a distribution list of the firms that were solicited. Documentation of MBE/WBE quotations shall be a part of the good faith effort submittal. This documentation may include written subcontractor quotations, telephone log notations of verbal quotations, or other types of quotation documentation.

Consideration of Good Faith Effort for Projects with a Combined MBE/WBE Goal More Than Zero

Adequate good faith efforts mean that the bidder took all necessary and reasonable steps to achieve the goal which, by their scope, intensity, and appropriateness, could reasonably be expected to obtain sufficient MBE/WBE participation. Adequate good faith efforts also mean that the bidder actively and aggressively sought MBE/WBE participation. Mere *pro forma* efforts are not considered good faith efforts.

The Department will consider the quality, quantity, and intensity of the different kinds of efforts a bidder has made. Listed below are examples of the types of actions a bidder will take in making a good faith effort to meet the goals and are not intended to be exclusive or exhaustive, nor is it intended to be a mandatory checklist.

- (A) Soliciting through all reasonable and available means (e.g. attendance at pre-bid meetings, advertising, written notices, use of verifiable electronic means through the use of the NCDOT Directory of Transportation Firms) the interest of all certified MBEs/WBEs that are also prequalified subcontractors. The bidder must solicit this interest within at least 10 days prior to bid opening to allow the MBEs/WBEs to respond to the solicitation. Solicitation shall provide the opportunity to MBEs/WBEs within the Division and surrounding Divisions where the project is located. The bidder must determine with certainty if the MBEs/WBEs are interested by taking appropriate steps to follow up initial solicitations.

- (B) Selecting portions of the work to be performed by MBEs/WBEs in order to increase the likelihood that the Combined MBE/WBE goal will be achieved.
 - (1) Where appropriate, break out contract work items into economically feasible units to facilitate MBE/WBE participation, even when the prime contractor might otherwise prefer to perform these work items with its own forces.
 - (2) Negotiate with subcontractors to assume part of the responsibility to meet the advertised goal when the work to be sublet includes potential for MBE/WBE participation (2nd and 3rd tier subcontractors).
- (C) Providing interested certified MBEs/WBEs that are also prequalified subcontractors with adequate information about the plans, specifications, and requirements of the contract in a timely manner to assist them in responding to a solicitation.
- (D)
 - (1) Negotiating in good faith with interested MBEs/WBEs. It is the bidder's responsibility to make a portion of the work available to MBE/WBE subcontractors and suppliers and to select those portions of the work or material needs consistent with the available MBE/WBE subcontractors and suppliers, so as to facilitate MBE/WBE participation. Evidence of such negotiation includes the names, addresses, and telephone numbers of MBEs/WBEs that were considered; a description of the information provided regarding the plans and specifications for the work selected for subcontracting; and evidence as to why additional agreements could not be reached for MBEs/WBEs to perform the work.
 - (2) A bidder using good business judgment would consider a number of factors in negotiating with subcontractors, including MBE/WBE subcontractors, and would take a firm's price and capabilities as well as the advertised goal into consideration. However, the fact that there may be some additional costs involved in finding and using MBEs/WBEs is not in itself sufficient reason for a bidder's failure to meet the advertised goal, as long as such costs are reasonable. Also, the ability or desire of a prime contractor to perform the work of a contract with its own organization does not relieve the bidder of the responsibility to make good faith efforts. Bidding contractors are not, however, required to accept higher quotes from MBEs/WBEs if the price difference is excessive or unreasonable.
- (E) Not rejecting MBEs/WBEs as being unqualified without sound reasons based on a thorough investigation of their capabilities. The bidder's standing within its industry, membership in specific groups, organizations, or associates and political or social affiliations (for example, union vs. non-union employee status) are not legitimate causes for the rejection or non-solicitation of bids in the bidder's efforts to meet the project goal.
- (F) Making efforts to assist interested MBEs/WBEs in obtaining bonding, lines of credit, or insurance as required by the recipient or bidder.
- (G) Making efforts to assist interested MBEs/WBEs in obtaining necessary equipment, supplies, materials, or related assistance or services.

- (H) Effectively using the services of available minority/women community organizations; minority/women contractors' groups; Federal, State, and local minority/women business assistance offices; and other organizations as allowed on a case-by-case basis to provide assistance in the recruitment and placement of MBEs/WBEs. Contact within 7 days from the bid opening the Business Opportunity and Work Force Development Unit at BOWD@ncdot.gov to give notification of the bidder's inability to get MBE or WBE quotes.
- (I) Any other evidence that the bidder submits which shows that the bidder has made reasonable good faith efforts to meet the advertised goal.

In addition, the Department may take into account the following:

- (1) Whether the bidder's documentation reflects a clear and realistic plan for achieving the Combined MBE/WBE goal.
- (2) The bidders' past performance in meeting the contract goal.
- (3) The performance of other bidders in meeting the advertised goal. For example, when the apparent successful bidder fails to meet the goal, but others meet it, you may reasonably raise the question of whether, with additional reasonable efforts the apparent successful bidder could have met the goal. If the apparent successful bidder fails to meet the advertised goal, but meets or exceeds the average MBE and WBE participation obtained by other bidders, the Department may view this, in conjunction with other factors, as evidence of the apparent successful bidder having made a good faith effort.

If the Department does not award the contract to the apparent lowest responsive bidder, the Department reserves the right to award the contract to the next lowest responsive bidder that can satisfy to the Department that the Combined MBE/WBE goal can be met or that an adequate good faith effort has been made to meet the advertised goal.

Non-Good Faith Appeal

The Engineer will notify the Contractor verbally and in writing of non-good faith. A Contractor may appeal a determination of non-good faith made by the Goal Compliance Committee. If a Contractor wishes to appeal the determination made by the Committee, they shall provide written notification to the Engineer. The appeal shall be made within 2 business days of notification of the determination of non-good faith.

Counting MBE/WBE Participation Toward Meeting the Combined MBE/WBE Goal

(A) Participation

The total dollar value of the participation by a committed MBE/WBE will be counted toward the contract goal requirements. The total dollar value of participation by a committed MBE/WBE will be based upon the value of work performed by the MBE/WBE and the actual payments to MBE/WBE firms by the Contractor.

(B) Joint Checks

Prior notification of joint check use shall be required when counting MBE/WBE participation for services or purchases that involves the use of a joint check. Notification shall be through submission of Form JC-1 (*Joint Check Notification Form*) and the use of joint checks shall be in accordance with the Department's Joint Check Procedures.

(C) Subcontracts (Non-Trucking)

A MBE/WBE may enter into subcontracts. Work that a MBE subcontracts to another MBE firm may be counted toward the anticipated MBE participation. The same holds for work that a WBE subcontracts to another WBE firm. Work that a MBE/WBE subcontracts to a non-MBE/WBE firm does not count toward the contract goal requirement. It should be noted that every effort shall be made by MBE and WBE contractors to subcontract to the same certification (i.e., MBEs to MBEs and WBEs to WBEs), in order to fulfill the MBE or WBE participation breakdown. This, however, may not always be possible due to the limitation of firms in the area. If the MBE or WBE firm shows a good faith effort has been made to reach out to similarly certified firms and there is no interest or availability, and they can get assistance from other certified firms, the Engineer will not hold the prime responsible for meeting the individual MBE or WBE breakdown. If a MBE or WBE contractor or subcontractor subcontracts a significantly greater portion of the work of the contract than would be expected on the basis of standard industry practices, it shall be presumed that the MBE or WBE is not performing a commercially useful function.

(D) Joint Venture

When a MBE or WBE performs as a participant in a joint venture, the Contractor may count toward its contract goal requirement a portion of the total value of participation with the MBE or WBE in the joint venture, that portion of the total dollar value being a distinct clearly defined portion of work that the MBE or WBE performs with its forces.

(E) Manufacturer, Regular Dealer, Distributor

A Contractor may count toward its MBE/WBE requirement 40 percent of its expenditures for materials or supplies (including transportation costs) from a MBE/WBE distributor, 60 percent of its expenditures for materials or supplies (including transportation costs) from a MBE/WBE regular dealer and 100 percent of such expenditures obtained from a MBE/WBE manufacturer.

A Contractor may count toward its MBE/WBE requirement the following expenditures to MBE/WBE firms that are not manufacturers, regular dealers or distributors:

- (1) The fees or commissions charged by a MBE/WBE firm for providing a *bona fide* service, such as professional, technical, consultant, or managerial services, or for providing bonds or insurance specifically required for the performance of a DOT-assisted contract, provided the fees or commissions are determined to be

reasonable and not excessive as compared with fees and commissions customarily allowed for similar services.

- (2) With respect to materials or supplies purchased from a MBE/WBE, which is neither a manufacturer, regular dealer, nor a distributor count the entire amount of fees or commissions charged that the Department deems to be reasonable, including transportation charges for the delivery of materials or supplies. Do not count any portion of the cost of the materials and supplies themselves.

A Contractor will submit a completed *DBE Regular Dealer/Distributor Affirmation Form* with the Letter of Intent to the Engineer. The Engineer will forward to the State Contractor Utilization Engineer or DBE@ncdot.gov. The State Contractor Utilization Engineer will make a preliminary assessment as to whether a MBE/WBE supplier has the demonstrated capacity to perform a commercially useful function (CUF) on a contract-by-contract basis *prior* to its participation.

Commercially Useful Function

(A) MBE/WBE Utilization

The Contractor may count toward its contract goal requirement only expenditures to MBEs and WBEs that perform a commercially useful function in the work of a contract. A MBE/WBE performs a commercially useful function when it is responsible for execution of the work of the contract and is carrying out its responsibilities by performing, managing, and supervising the work involved. To perform a commercially useful function, the MBE/WBE shall also be responsible with respect to materials and supplies used on the contract, for negotiating price, determining quality and quantity, ordering the material and installing (where applicable) and paying for the material itself. To determine whether a MBE/WBE is performing a commercially useful function, the Department will evaluate the amount of work subcontracted, industry practices, whether the amount the firm is to be paid under the contract is commensurate with the work it is performing and the MBE/WBE credit claimed for its performance of the work, and any other relevant factors. If it is determined that a MBE or WBE is not performing a Commercially Useful Function, the contractor may present evidence to rebut this presumption to the Department.

(B) MBE/WBE Utilization in Trucking

The following factors will be used to determine if a MBE or WBE trucking firm is performing a commercially useful function:

- (1) The MBE/WBE shall be responsible for the management and supervision of the entire trucking operation for which it is responsible on a particular contract, and there shall not be a contrived arrangement for the purpose of meeting the Combined MBE/WBE goal.
- (2) The MBE/WBE shall itself own and operate at least one fully licensed, insured, and operational truck used on the contract.

- (3) The MBE/WBE receives credit for the total value of the transportation services it provides on the contract using trucks it owns, insures, and operates using drivers it employs.
- (4) The MBE may subcontract the work to another MBE firm, including an owner-operator who is certified as a MBE. The same holds true that a WBE may subcontract the work to another WBE firm, including an owner-operator who is certified as a WBE. When this occurs, the MBE or WBE who subcontracts work receives credit for the total value of the transportation services the subcontracted MBE or WBE provides on the contract. It should be noted that every effort shall be made by MBE and WBE contractors to subcontract to the same certification (i.e., MBEs to MBEs and WBEs to WBEs), in order to fulfill the participation breakdown. This, however, may not always be possible due to the limitation of firms in the area. If the MBE or WBE firm shows a good faith effort has been made to reach out to similarly certified transportation service providers and there is no interest or availability, and they can get assistance from other certified providers, the Engineer will not hold the prime responsible for meeting the individual MBE or WBE participation breakdown.
- (5) The MBE/WBE may also subcontract the work to a non-MBE/WBE firm, including from an owner-operator. The MBE/WBE who subcontracts the work to a non-MBE/WBE is entitled to credit for the total value of transportation services provided by the non-MBE/WBE subcontractor not to exceed the value of transportation services provided by MBE/WBE-owned trucks on the contract. Additional participation by non-MBE/WBE subcontractors receives credit only for the fee or commission it receives as a result of the subcontract arrangement. The value of services performed under subcontract agreements between the MBE/WBE and the Contractor will not count towards the MBE/WBE contract requirement.
- (6) A MBE/WBE may lease truck(s) from an established equipment leasing business open to the general public. The lease must indicate that the MBE/WBE has exclusive use of and control over the truck. This requirement does not preclude the leased truck from working for others during the term of the lease with the consent of the MBE/WBE, so long as the lease gives the MBE/WBE absolute priority for use of the leased truck. This type of lease may count toward the MBE/WBE's credit as long as the driver is under the MBE/WBE's payroll.
- (7) Subcontracted/leased trucks shall display clearly on the dashboard the name of the MBE/WBE that they are subcontracted/leased to and their own company name if it is not identified on the truck itself. Magnetic door signs are not permitted.

MBE/WBE Replacement

When a Contractor has relied on a commitment to a MBE or WBE subcontractor (or an approved substitute MBE or WBE subcontractor) to meet all or part of a contract goal requirement, the contractor shall not terminate the MBE/WBE subcontractor or any portion of its work for convenience. This includes, but is not limited to, instances in which the Contractor seeks to

perform the work of the terminated subcontractor with another MBE/WBE subcontractor, a non-MBE/WBE subcontractor, or with the Contractor's own forces or those of an affiliate.

The Contractor must give notice in writing both by certified mail and email to the MBE/WBE subcontractor, with a copy to the Engineer of its intent to request to terminate a MBE/WBE subcontractor or any portion of its work, and the reason for the request. The Contractor must give the MBE/WBE subcontractor five (5) business days to respond to the Contractor's Notice of Intent to Request Termination and/or Substitution. If the MBE/WBE subcontractor objects to the intended termination/substitution, the MBE/WBE, within five (5) business days must advise the Contractor and the Department of the reasons why the action should not be approved. The five-day notice period shall begin on the next business day after written notice is provided to the MBE/WBE subcontractor.

A committed MBE/WBE subcontractor may only be terminated or any portion of its work after receiving the Department's written approval based upon a finding of good cause for the proposed termination and/or substitution. Good cause does not exist if the Contractor seeks to terminate a MBE/WBE or any portion of its work that it relied upon to obtain the contract so that the Contractor can self-perform the work for which the MBE/WBE was engaged, or so that the Contractor can substitute another MBE/WBE or non-MBE/WBE contractor after contract award. For purposes of this section, good cause shall include the following circumstances:

- (a) The listed MBE/WBE subcontractor fails or refuses to execute a written contract;
- (b) The listed MBE/WBE subcontractor fails or refuses to perform the work of its subcontract in a way consistent with normal industry standards. Provided, however, that good cause does not exist if the failure or refusal of the MBE/WBE subcontractor to perform its work on the subcontract results from the bad faith or discriminatory action of the prime contractor;
- (c) The listed MBE/WBE subcontractor fails or refuses to meet the prime contractor's reasonable, nondiscriminatory bond requirements;
- (d) The listed MBE/WBE subcontractor becomes bankrupt, insolvent, or exhibits credit unworthiness;
- (e) The listed MBE/WBE subcontractor is ineligible to work on public works projects because of suspension and debarment proceedings pursuant to 2 CFR parts 180, 215 and 1200 or applicable State law;
- (f) The listed MBE/WBE subcontractor is not a responsible contractor;
- (g) The listed MBE/WBE voluntarily withdraws from the project and provides written notice of withdrawal;
- (h) The listed MBE/WBE is ineligible to receive MBE/WBE credit for the type of work required;
- (i) A MBE/WBE owner dies or becomes disabled with the result that the listed MBE/WBE contractor is unable to complete its work on the contract; and
- (j) Other documented good cause that compels the termination of the MBE/WBE subcontractor.

The Contractor shall comply with the following for replacement of a committed MBE/WBE:

(A) Performance Related Replacement

When a committed MBE/WBE is terminated for good cause as stated above, an additional MBE/WBE that was submitted at the time of bid may be used to fulfill the MBE/WBE commitment to meet the Combined MBE/WBE Goal. A good faith effort will only be required for removing a committed MBE/WBE if there were no additional MBE/WBEs submitted at the time of bid to cover the same amount of work as the MBE/WBE that was terminated.

If a replacement MBE/WBE is not found that can perform at least the same amount of work as the terminated MBE/WBE, the Contractor shall submit a good faith effort documenting the steps taken. Such documentation shall include, but not be limited to, the following:

- (1) Copies of written notification to MBE/WBEs that their interest is solicited in contracting the work defaulted by the previous MBE/WBE or in subcontracting other items of work in the contract.
- (2) Efforts to negotiate with MBE/WBEs for specific subbids including, at a minimum:
 - (a) The names, addresses, and telephone numbers of MBE/WBEs who were contacted.
 - (b) A description of the information provided to MBE/WBEs regarding the plans and specifications for portions of the work to be performed.
- (3) A list of reasons why MBE/WBE quotes were not accepted.
- (4) Efforts made to assist the MBE/WBEs contacted, if needed, in obtaining bonding or insurance required by the Contractor.

(B) Decertification Replacement

- (1) When a committed MBE/WBE is decertified by the Department after the SAF (*Subcontract Approval Form*) has been received by the Department, the Department will not require the Contractor to solicit replacement MBE/WBE participation equal to the remaining work to be performed by the decertified firm. The participation equal to the remaining work performed by the decertified firm will count toward the contract goal requirement but not the overall goal.
 - (i) If the MBE/WBE's ineligibility is caused solely by its having exceeded the size standard during the performance of the contract. The Department may continue to count participation equal to the remaining work performed by the decertified firm which will count toward the contract goal requirement and overall goal.

- (ii) If the MBE/WBE's ineligibility is caused solely by its acquisition by or merger with a non- MBE/WBE during the performance of the contract. The Department may not continue to count the portion of the decertified firm's performance on the contract remaining toward either the contract goal or the overall goal, even if the Contractor has executed a subcontract with the firm or the Department has executed a prime contract with the MBE/WBE that was later decertified.
- (2) When a committed MBE/WBE is decertified prior to the Department receiving the SAF (*Subcontract Approval Form*) for the named MBE/WBE firm, the Contractor shall take all necessary and reasonable steps to replace the MBE/WBE subcontractor with another MBE/WBE subcontractor to perform at least the same amount of work to meet the Combined MBE/WBE goal requirement. If a MBE/WBE firm is not found to do the same amount of work, a good faith effort must be submitted to NCDOT (see A herein for required documentation).

All requests for replacement of a committed MBE/WBE firm shall be submitted to the Engineer for approval on Form RF-1 (*DBE Replacement Request*). If the Contractor fails to follow this procedure, the Contractor may be disqualified from further bidding for a period of up to 6 months.

Changes in the Work

When the Engineer makes changes that result in the reduction or elimination of work to be performed by a committed MBE/WBE, the Contractor will not be required to seek additional participation. When the Engineer makes changes that result in additional work to be performed by a MBE/WBE based upon the Contractor's commitment, the MBE/WBE shall participate in additional work to the same extent as the MBE/WBE participated in the original contract work.

When the Engineer makes changes that result in extra work, which has more than a minimal impact on the contract amount, the Contractor shall seek additional participation by MBEs/WBEs unless otherwise approved by the Engineer.

When the Engineer makes changes that result in an alteration of plans or details of construction, and a portion or all of the work had been expected to be performed by a committed MBE/WBE, the Contractor shall seek participation by MBEs/WBEs unless otherwise approved by the Engineer.

When the Contractor requests changes in the work that result in the reduction or elimination of work that the Contractor committed to be performed by a MBE/WBE, the Contractor shall seek additional participation by MBEs/WBEs equal to the reduced MBE/WBE participation caused by the changes.

Reports and Documentation

A SAF (*Subcontract Approval Form*) shall be submitted for all work which is to be performed by a MBE/WBE subcontractor. The Department reserves the right to require copies of actual subcontract agreements involving MBE/WBE subcontractors.

When using transportation services to meet the contract commitment, the Contractor shall submit a proposed trucking plan in addition to the SAF. The plan shall be submitted prior to beginning construction on the project. The plan shall include the names of all trucking firms proposed for use, their certification type(s), the number of trucks owned by the firm, as well as the individual truck identification numbers, and the line item(s) being performed.

Within 30 calendar days of entering into an agreement with a MBE/WBE for materials, supplies or services, not otherwise documented by the SAF as specified above, the Contractor shall furnish the Engineer a copy of the agreement. The documentation shall also indicate the percentage (60% or 100%) of expenditures claimed for MBE/WBE credit.

Reporting Minority and Women Business Enterprise Participation

The Contractor shall provide the Engineer with an accounting of payments made to all MBE and WBE firms, including material suppliers and contractors at all levels (prime, subcontractor, or second tier subcontractor). This accounting shall be furnished to the Engineer for any given month by the end of the following month. Failure to submit this information accordingly may result in the following action:

- (A) Withholding of money due in the next partial pay estimate; or
- (B) Removal of an approved contractor from the prequalified bidders' list or the removal of other entities from the approved subcontractors list.

While each contractor (prime, subcontractor, 2nd tier subcontractor) is responsible for accurate accounting of payments to MBEs/WBEs, it shall be the prime contractor's responsibility to report all monthly and final payment information in the correct reporting manner.

Failure on the part of the Contractor to submit the required information in the time frame specified may result in the disqualification of that contractor and any affiliate companies from further bidding until the required information is submitted.

Failure on the part of any subcontractor to submit the required information in the time frame specified may result in the disqualification of that contractor and any affiliate companies from being approved for further work on future projects until the required information is submitted.

Contractors reporting transportation services provided by non-MBE/WBE lessees shall evaluate the value of services provided during the month of the reporting period only.

At any time, the Engineer can request written verification of subcontractor payments. The Contractor shall report the accounting of payments through the Department's DBE Payment Tracking System.

Failure to Meet Contract Requirements

Failure to meet contract requirements in accordance with Subarticle 102-15(J) of the *Standard Specifications* may be cause to disqualify the Contractor.

MULTI-YEAR MAINTENANCE CONTRACTS (ID/IQ):

(4-20-21) (Rev. 4-19-22)

SP1 G75

This contract is a multi-year maintenance contract let pursuant to the provisions of N.C. General Statute §136-28.1(b). No minimum quantity of services is guaranteed to be awarded bidders under this contract. In accordance with N.C. General Statute §136-28.1(b), an award in a maintenance contract may be for an amount less but shall not exceed \$5,000,000 per year. No payments in excess of this amount will be disbursed, in accordance with the Statute.

RESTRICTIONS ON ITS EQUIPMENT AND SERVICES:

(11-17-20)

SP01 G090

All telecommunications, video or other ITS equipment or services installed or utilized on this project must be in conformance with UNIFORM ADMINISTRATIVE REQUIREMENTS, COST PRINCIPLES, AND AUDIT REQUIREMENTS FOR FEDERAL AWARDS 2 CFR, § 200.216 **Prohibition on certain telecommunications and video surveillance services or equipment.**

USE OF UNMANNED AIRCRAFT SYSTEM (UAS):

(8-20-19)(Rev. 3-17-26)

SP1 G092

The Contractor shall adhere to all Federal, State and Local regulations and guidelines for the use of Unmanned Aircraft Systems (UAS). This includes but is not limited to US 14 CFR Part 107, NC GS 15A-300, American Security Drone Act of 2023 (ASDA), Office of Management and Budget (OMB) Memorandum M-26-02, all FAA rules, regulations and policies and all NCDOT UAS Policies. The required operator certifications include possessing a current Federal Aviation Administration (FAA) Remote Pilot Certificate, as well as operating a UAS registered with the FAA.

All UAS operations shall be approved by the Engineer prior to beginning the operations.

All contractors or subcontractors operating UAS shall have UAS specific general liability insurance to cover all operations under this contract.

The use of UAS is at the Contractor's discretion. No measurement or payment will be made for the use of UAS. In the event that the Department directs the Contractor to utilize UAS, payment will be in accordance with Article 104-7 Extra Work.

EQUIPMENT IDLING GUIDELINES:

(1-19-21)

107

SP1 G096

Exercise reduced fuel consumption and reduced equipment emissions during the construction of all work associated with this contract. Employees engaged in the construction of this project should turn off vehicles when stopped for more than thirty (30) minutes and off-highway equipment should idle no longer than fifteen (15) consecutive minutes.

These guidelines for turning off vehicles and equipment when idling do not apply to:

1. Idling when queuing.
2. Idling to verify the vehicle is in safe operating condition.

3. Idling for testing, servicing, repairing or diagnostic purposes.
4. Idling necessary to accomplish work for which the vehicle was designed (such as operating a crane, mixing concrete, etc.).
5. Idling required to bring the machine system to operating temperature.
6. Emergency vehicles, utility company, construction, and maintenance vehicles where the engines must run to perform needed work.
7. Idling to ensure safe operation of the vehicle.
8. Idling when the propulsion engine is providing auxiliary power for other than heating or air conditioning. (such as hydraulic systems for pavers)
9. When specific traffic, safety, or emergency situations arise.
10. If the ambient temperature is less than 32 degrees Fahrenheit. Limited idling to provide for the safety of vehicle occupants (e.g. to run the heater).
11. If the ambient temperature is greater than 90 degrees Fahrenheit. Limited idling to provide for the safety of vehicle occupants of off-highway equipment (e.g. to run the air conditioning) no more than 30 minutes.
12. Diesel powered vehicles may idle for up to 30 minutes to minimize restart problems.

Any vehicle, truck, or equipment in which the primary source of fuel is natural gas or electricity is exempt from the idling limitations set forth in this special provision.

OUTSOURCING OUTSIDE THE USA:

(9-21-04) (Rev. 5-16-06)

SP1 G150

All work on consultant contracts, services contracts, and construction contracts shall be performed in the United States of America. No work shall be outsourced outside of the United States of America.

Outsourcing for the purpose of this provision is defined as the practice of subcontracting labor, work, services, staffing, or personnel to entities located outside of the United States.

The North Carolina Secretary of Transportation shall approve exceptions to this provision in writing.

NOTES TO CONTRACTOR:

(8-19-25)

SP1 G999B

Plans for the existing lighting installation will be available for reference upon the bidder request. These plans may provide for technical, schematic, or materials information.

Any change resulting in an increase in lighting lumens from the original design requires consultation and written approval of Division 14 Environmental Office staff.

PROJECT SPECIAL PROVISIONS**ROADWAY****ELECTRICAL JUNCTION BOXES:**

(6-18-24)

1091

SP10 R91

Revise the *Standard Specifications* as follows:

Page 10-209, Subarticle 1091-5(A) General, add the following after line 27:

Boxes and covers shall meet all requirements and specifications of ANSI/SCTE 77. Structural load tests shall meet the Tier 15 application type.

Page 10-209, Subarticle 1091-5(B) Polymer Concrete (PC) Junction Boxes, lines 28, delete and replace the subarticle title with the following:

(B) Polymer Concrete (PC), Composite and Thermoplastic Junction Boxes

Page 10-209, Subarticle 1091-5(B) Polymer Concrete (PC) Junction Boxes, add the following after line 28:

For PC junction boxes, use polymer concrete material made of an aggregate consisting of sand and gravel bound together with a polymer and reinforced with glass strands to fabricate box and cover components.

Page 10-209, Subarticle 1091-5(B) Polymer Concrete (PC) Junction Boxes, line 29 replace “polymer concrete (PC) boxes” with “junction boxes”.

Page 10-209, Subarticle 1091-5(B) Polymer Concrete (PC) Junction Boxes, lines 31-37, delete the second and third paragraph.

Page 10-209, Subarticle 1091-5(B) Polymer Concrete (PC) Junction Boxes, lines 40-41, delete the fourth sentence of the fourth paragraph and replace with the following:

Bodies of junction boxes shall be a single piece.

Polymer concrete, composite and thermoplastic junction boxes are not required to be listed electrical devices.

WORK ZONE INSTALLER:

(7-20-21)(Rev. 4-21-26)

1101

SP11 R04

Revise the *Standard Specifications* as follows:

Page 11-4, Article 1101-14 WORK ZONE INSTALLER, lines 25-26, delete the first sentence of the first paragraph and replace with the following:

When temporary traffic control consists of more than flagging operations, the Contractor shall provide the service of at least one qualified work zone installer during the setup, installation, and removal of temporary traffic control within the highway right of way.

STANDARD SPECIAL PROVISION**AVAILABILITY OF FUNDS – TERMINATION OF CONTRACTS**

(5-20-08)(Rev. 1-16-24)

Z-2

General Statute 143C-6-11. (h) Highway Appropriation is hereby incorporated verbatim in this contract as follows:

(h) Amounts Encumbered. – Transportation project appropriations may be encumbered in the amount of allotments made to the Department of Transportation by the Director for the estimated payments for transportation project contract work to be performed in the appropriation fiscal year. The allotments shall be multiyear allotments and shall be based on estimated revenues and shall be subject to the maximum contract authority contained in *General Statute 143C-6-11(c)*. Payment for transportation project work performed pursuant to contract in any fiscal year other than the current fiscal year is subject to appropriations by the General Assembly. Transportation project contracts shall contain a schedule of estimated completion progress, and any acceleration of this progress shall be subject to the approval of the Department of Transportation provided funds are available. The State reserves the right to terminate or suspend any transportation project contract, and any transportation project contract shall be so terminated or suspended if funds will not be available for payment of the work to be performed during that fiscal year pursuant to the contract. In the event of termination of any contract, the contractor shall be given a written notice of termination at least 60 days before completion of scheduled work for which funds are available. In the event of termination, the contractor shall be paid for the work already performed in accordance with the contract specifications.

Payment will be made on any contract terminated pursuant to the special provision in accordance with Subarticle 108-13(D) of the *Standard Specifications*.

STANDARD SPECIAL PROVISION
ERRATA

(1-16-24)(Rev. 6-16-26)

Z-4

Revise the *2024 Standard Specifications* as follows:

Division 1

Page 1-1, Article 101-2 ABBREVIATIONS, line 25, replace "American Wood-Preservers' Association" with "American Wood Protection Association".

Page 1-18, Article 102-10 BID BOND OR BID DEPOSIT, line 26, replace " Subarticle 102-8(A)(8)(b)" with "Subarticle 102-8(A)(12)(b)".

Page 1-20, Subarticle 102-14(A) State Funded Projects, line 3, replace "\$30,000" with "\$40,000".

Page 1-20, Subarticle 102-14(B) Federal Aid Projects, line 7, replace "\$30,000" with "\$40,000".

Page 1-36, Subarticle 104-12(B) Evaluation of Proposals, line 21, replace "Design-Build Unit" with "Alternative Delivery Unit".

Page 1-36, Subarticle 104-12(D) Preliminary Review, line 37, replace "Design-Build Unit" with "Alternative Delivery Unit".

Page 1-37, Subarticle 104-12(E) Final Proposal, line 3, replace "Design-Build Unit" with "Alternative Delivery Unit".

Page 1-37, Subarticle 104-12(F) Design-Build VEPs, line 36, replace "Design-Build Unit" with "Alternative Delivery Unit".

Page 1-38, Subarticle 104-12(G) Modifications, line 1, replace "Design-Build Unit" with "Alternative Delivery Unit".

Division 3

Page 3-5, Article 305-2 MATERIALS, after line 16, replace " 1032-3(A)(7)" with "1032-3" and add the item "Galvanized Corrugated Steel Pipe" with Section "1032-3".

Page 3-6, Article 310-2 MATERIALS, after line 9, add the item "Galvanized Corrugated Steel Pipe" with Section "1032-3".

Division 6

Page 6-15, Article 610-1 DESCRIPTION, line 20, replace "The work includes" with "The work includes, but is not limited to,".

Page 6-15, Article 610-1 DESCRIPTION, line 22, replace “applying the tack coat as specified.” with “applying the tack coat in accordance with Section 605.”.

Page 6-30, Article 610-14 DENSITY ACCEPTANCE, line 39, replace “QC process.” with “QC process in accordance with Section 609.”.

Page 6-31, Article 610-16 MEASUREMENT AND PAYMENT, line 13, replace "*Hot Mix Asphalt Pavement*" with "*Asphalt Concrete _____ Course, Type _____*".

Page 6-50, Subarticle 661-4(A) Equipment, lines 4-7, replace the first two sentences of the seventh paragraph with the following:

When an erected fixed stringline is utilized for longitudinal profile and cross slope control furnish and erect the necessary guide line for the equipment.

Division 7

Page 7-18, Subarticle 710-10(A) General, lines 7-8, delete “for *Surface Testing Concrete Pavement*” from the last paragraph.

Division 8

Page 8-27, Article 846-1 DESCRIPTION, line 8, delete “4 inch” from the first paragraph.

Division 9

Page 9-17, Article 904-4 MEASUREMENT AND PAYMENT, prior to line 1, replace " Sign Erection, Relocate Type (Ground Mounted)" with “Sign Erection, Relocate Type ____ (Ground Mounted)”.

Division 10

Page 10-51, Article 1024-4 WATER, prior to line 1, delete the “unpopulated blank row” in Table 1024-2 between “Time of set, deviation from control” and “Chloride Ion Content, Max.”.

Page 10-170, Subarticle 1081-1(C) Requirements, line 4, replace "maximum" with “minimum”.

Division 11

Page 11-15, Article 1160-4 MEASUREMENT AND PAYMENT, line 24, replace “Where barrier units are moved more than one” with “Where barrier units are moved more than once”.

Division 15

Page 15-10, Article 1515-4 MEASUREMENT AND PAYMENT, lines 11, replace " All piping" with “All labor, the manhole, other materials, excavation, backfilling, piping”.

Division 16

Page 16-14, Article 1633-5 MEASUREMENT AND PAYMENT, line 20-24 and prior to line 25, delete and replace with the following " *Flocculant* will be measured and paid in accordance with Article 1642-5 applied to the temporary rock silt checks."

Page 16-3, Article 1609-2 MATERIALS, after line 26, replace "Type 4" with "Type 4a".

Page 16-25, Article 1644-2 MATERIALS, after line 22, replace "Type 4" with "Type 4a".

Page 16-27, Article 1644-5 MEASUREMENT AND PAYMENT, line 31, replace "Article 1630-4" with "Article 1630-3".

Division 17

Page 17-15, Article 1715-4 MEASUREMENT AND PAYMENT, line 23, delete and replace "1.25" with "1-1/4".

Page 17-15, Article 1715-4 MEASUREMENT AND PAYMENT, line 24, delete and replace "(1.25" with " , 1-1/4".

STANDARD SPECIAL PROVISION**PLANT AND PEST QUARANTINES**

(Imported Fire Ant, Guava Root Knot Nematode, Spongy Moth (formerly known as gypsy moth), Witchweed, Cogon Grass, And Any Other Regulated Noxious Weed or Plant Pest)

(3-18-03)(Rev. 3-18-25)

Z-04a

Within Quarantined Area

This project may be within a county regulated for plant and/or pests. If the project or any part of the Contractor's operations is located within a quarantined area, thoroughly clean all equipment prior to moving out of the quarantined area. Comply with federal/state regulations by obtaining a certificate or limited permit for any regulated article moving from the quarantined area.

Originating in a Quarantined County

Obtain a certificate or limited permit issued by the N.C. Department of Agriculture/United States Department of Agriculture. Have the certificate or limited permit accompany the article when it arrives at the project site.

Contact

Contact the N.C. Department of Agriculture/United States Department of Agriculture at 1-800-206-9333, 919-707-3730, or <https://www.ncagr.gov/divisions/plant-industry/plant-protection/plant-industry-plant-pest-quarantines> to determine those specific project sites located in the quarantined area or for any regulated article used on this project originating in a quarantined county.

Regulated Articles Include

1. Soil, sand, gravel, compost, peat, humus, muck, and decomposed manure, separately or with other articles. This includes movement of articles listed above that may be associated with cut/waste, ditch pulling, and shoulder cutting.
2. Plants with roots including grass sod.
3. Plant crowns and roots.
4. Bulbs, corms, rhizomes, and tubers of ornamental plants.
5. Hay, straw, fodder, and plant litter of any kind.
6. Clearing and grubbing debris.
7. Used agricultural cultivating and harvesting equipment.
8. Used earth-moving equipment.
9. Any other products, articles, or means of conveyance of any character, if determined by an inspector present a hazard of spreading imported fire ant, guava root knot nematode, spongy moth (formerly known as gypsy moth), witchweed, cogon grass, or other regulated noxious weed or plant pest.

STANDARD SPECIAL PROVISION**MINIMUM WAGES**

(7-21-09)

Z-5

FEDERAL: The Fair Labor Standards Act provides that with certain exceptions every employer shall pay wages at the rate of not less than SEVEN DOLLARS AND TWENTY FIVE CENTS (\$7.25) per hour.

STATE: The North Carolina Minimum Wage Act provides that every employer shall pay to each of his employees, wages at a rate of not less than SEVEN DOLLARS AND TWENTY FIVE CENTS (\$7.25) per hour.

The minimum wage paid to all skilled labor employed on this contract shall be SEVEN DOLLARS AND TWENTY FIVE CENTS (\$7.25) per hour.

The minimum wage paid to all intermediate labor employed on this contract shall be SEVEN DOLLARS AND TWENTY FIVE CENTS (\$7.25) per hour.

The minimum wage paid to all unskilled labor on this contract shall be SEVEN DOLLARS AND TWENTY FIVE CENTS (\$7.25) per hour.

This determination of the intent of the application of this act to the contract on this project is the responsibility of the Contractor.

The Contractor shall have no claim against the Department of Transportation for any changes in the minimum wage laws, Federal or State. It is the responsibility of the Contractor to keep fully informed of all Federal and State Laws affecting his contract.

STANDARD SPECIAL PROVISION**TITLE VI AND NONDISCRIMINATION:**

(6-28-77)(Rev 1/16/2024)

Z-6

The North Carolina Department of Transportation is committed to carrying out the U.S. Department of Transportation's policy of ensuring nondiscrimination in the award and administration of contracts.

The provisions of this section related to United States Department of Transportation (US DOT) Order 1050.2A, Title 49 Code of Federal Regulations (CFR) part 21, 23 United States Code (U.S.C.) 140 and 23 CFR part 200 (or 49 CFR 303, 49 U.S.C. 5332 or 49 U.S.C. 47123) are applicable to all North Carolina Department of Transportation (NCDOT) contracts and to all related subcontracts, material supply, engineering, architectural and other service contracts, regardless of dollar amount. Any Federal provision that is specifically required not specifically set forth is hereby incorporated by reference.

(1) Title VI Assurances (USDOT Order 1050.2A, Appendix A)

During the performance of this contract, the contractor, for itself, its assignees, and successors in interest (hereinafter referred to as the "contractor") agrees as follows:

(a) Compliance with Regulations

The contractor (hereinafter includes consultants) shall comply with the Acts and the Regulations relative to Nondiscrimination in Federally-assisted programs of the U.S. Department of Transportation, Federal Highway Administration (FHWA), as they may be amended from time to time, which are herein incorporated by reference and made a part of this contract.

(b) Nondiscrimination

The contractor, with regard to the work performed by it during the contract, shall not discriminate on the grounds of race, color, or national origin in the selection and retention of subcontractors, including procurements of materials and leases of equipment. The contractor shall not participate directly or indirectly in the discrimination prohibited by the Acts and the Regulations, including employment practices when the contract covers any activity, project, or program set forth in Appendix B of 49 CFR Part 21.

(c) Solicitations for Subcontractors, Including Procurements of Materials and Equipment

In all solicitations, either by competitive bidding, or negotiation made by the contractor for work to be performed under a subcontract, including procurements of materials, or leases of equipment, each potential subcontractor or supplier shall be notified by the contractor of the contractor's obligations under this contract and the Acts and the Regulations relative to Nondiscrimination on the grounds of race, color, or national origin.

(d) Information and Reports

The contractor shall provide all information and reports required by the Acts, the Regulations, and directives issued pursuant thereto and shall permit access to its books, records, accounts, other sources of information, and its facilities as may be determined

by the Recipient or the FHWA to be pertinent to ascertain compliance with such Acts, Regulations, and instructions. Where any information required of a contractor is in the exclusive possession of another who fails or refuses to furnish the information, the contractor shall so certify to the Recipient or the FHWA, as appropriate, and shall set forth what efforts it has made to obtain the information.

(e) Sanctions for Noncompliance:

In the event of a contractor's noncompliance with the Non-discrimination provisions of this contract, the Recipient will impose such contract sanctions as it and/or the FHWA may determine to be appropriate, including, but not limited to:

- (i) Withholding payments to the contractor under the contract until the contractor complies; and/or
- (ii) Cancelling, terminating, or suspending a contract, in whole or in part.

(f) Incorporation of Provisions

The contractor shall include the provisions of paragraphs (a) through (f) in every subcontract, including procurements of materials and leases of equipment, unless exempt by the Acts, the Regulations and directives issued pursuant thereto. The contractor shall take action with respect to any subcontract or procurement as the Recipient or the FHWA may direct as a means of enforcing such provisions including sanctions for noncompliance. Provided, that if the contractor becomes involved in, or is threatened with litigation by a subcontractor, or supplier because of such direction, the contractor may request the Recipient to enter into any litigation to protect the interests of the Recipient. In addition, the contractor may request the United States to enter into the litigation to protect the interests of the United States.

(2) Title VI Nondiscrimination Program (23 CFR 200.5(p))

The North Carolina Department of Transportation (NCDOT) has assured the USDOT that, as a condition to receiving federal financial assistance, NCDOT will comply with Title VI of the Civil Rights Act of 1964 and all requirements imposed by Title 49 CFR part 21 and related nondiscrimination authorities to ensure that no person shall, on the ground of race, color, national origin, limited English proficiency, sex, age, or disability (including religion/creed or income-level, where applicable), be excluded from participation in, be denied the benefits of, or be subjected to discrimination under any programs, activities, or services conducted or funded by NCDOT. Contractors and other organizations under contract or agreement with NCDOT must also comply with Title VI and related authorities, therefore:

- (a) During the performance of this contract or agreement, contractors (e.g., subcontractors, consultants, vendors, prime contractors) are responsible for complying with NCDOT's Title VI Program. Contractors are not required to prepare or submit Title VI Programs. To comply with this section, the prime contractor shall:
 - 1. Post NCDOT's Notice of Nondiscrimination and the Contractor's own Equal Employment Opportunity (EEO) Policy in conspicuous locations accessible to all employees, applicants and subcontractors on the jobsite.

2. Physically incorporate the required Title VI clauses into all subcontracts on federally-assisted and state-funded NCDOT projects, and ensure inclusion by subcontractors into all lower-tier subcontracts.
 3. Required Solicitation Language. The Contractor shall include the following notification in all solicitations for bids and requests for work or material, regardless of funding source:

“The North Carolina Department of Transportation, in accordance with the provisions of Title VI of the Civil Rights Act of 1964 (78 Stat. 252, 42 U.S.C. §§ 2000d to 2000d-4) and the Regulations, hereby notifies all bidders that it will affirmatively ensure that any contract entered into pursuant to this advertisement, disadvantaged business enterprises will be afforded full and fair opportunity to submit bids in response to this invitation and will not be discriminated against on the grounds of race, color, or national origin in consideration for an award. In accordance with other related nondiscrimination authorities, bidders and contractors will also not be discriminated against on the grounds of sex, age, disability, low-income level, creed/religion, or limited English proficiency in consideration for an award.”
 4. Physically incorporate the FHWA-1273, in its entirety, into all subcontracts and subsequent lower tier subcontracts on Federal-aid highway construction contracts only.
 5. Provide language assistance services (i.e., written translation and oral interpretation), free of charge, to LEP employees and applicants. Contact NCDOT OCR for further assistance, if needed.
 6. For assistance with these Title VI requirements, contact the NCDOT Title VI Nondiscrimination Program at 1-800-522-0453.
- (b) Subrecipients (e.g. cities, counties, LGAs, planning organizations) may be required to prepare and submit a Title VI Plan to NCDOT, including Title VI Assurances and/or agreements. Subrecipients must also ensure compliance by their contractors and subrecipients with Title VI. (23 CFR 200.9(b)(7))
- (c) If reviewed or investigated by NCDOT, the contractor or subrecipient agrees to take affirmative action to correct any deficiencies found within a reasonable time period, not to exceed 90 calendar days, unless additional time is granted by NCDOT. (23 CFR 200.9(b)(15))
- (d) The Contractor is responsible for notifying subcontractors of NCDOT’s External Discrimination Complaints Process.
1. Applicability

Title VI and related laws protect participants and beneficiaries (e.g., members of the public and contractors) from discrimination by NCDOT employees, subrecipients and contractors, regardless of funding source.

2. Eligibility

Any person—or class of persons—who believes he/she has been subjected to discrimination based on race, color, national origin, Limited English Proficiency (LEP), sex, age, or disability (and religion in the context of employment, aviation, or transit) may file a written complaint. The law also prohibits intimidation or retaliation of any sort.

3. Time Limits and Filing Options

Complaints may be filed by the affected individual(s) or a representative and must be filed no later than 180 calendar days after the following:

- (i) The date of the alleged act of discrimination; or
- (ii) The date when the person(s) became aware of the alleged discrimination; or
- (iii) Where there has been a continuing course of conduct, the date on which that conduct was discontinued or the latest instance of the conduct.

Title VI and related discrimination complaints may be submitted to the following entities:

- North Carolina Department of Transportation, Office of Civil Rights, Title VI Program, 1511 Mail Service Center, Raleigh, NC 27699-1511; toll free 1-800-522-0453
- Federal Highway Administration, North Carolina Division Office, 310 New Bern Avenue, Suite 410, Raleigh, NC 27601, 919-747-7010
- US Department of Transportation, Departmental Office of Civil Rights, External Civil Rights Programs Division, 1200 New Jersey Avenue, SE, Washington, DC 20590; 202-366-4070

4. Format for Complaints

Complaints must be in writing and signed by the complainant(s) or a representative, and include the complainant's name, address, and telephone number. Complaints received by fax or e-mail will be acknowledged and processed. Allegations received by telephone will be reduced to writing and provided to the complainant for confirmation or revision before processing. Complaints will be accepted in other languages, including Braille.

5. Discrimination Complaint Form

Contact NCDOT Civil Rights to receive a full copy of the Discrimination Complaint Form and procedures.

6. Complaint Basis

Allegations must be based on issues involving race, color, national origin (LEP), sex, age, disability, or religion (in the context of employment, aviation or transit). "Basis" refers to the complainant's membership in a protected group category.

**TABLE 103-1
COMPLAINT BASIS**

Protected Categories	Definition	Examples	Applicable Nondiscrimination Authorities
Race and Ethnicity	An individual belonging to one of the accepted racial groups; or the perception, based usually on physical characteristics that a person is a member of a racial group	Black/African American, Hispanic/Latino, Asian, American Indian/Alaska Native, Native Hawaiian/Pacific Islander, White	Title VI of the Civil Rights Act of 1964; 49 CFR Part 21; 23 CFR 200; 49 U.S.C. 5332(b); 49 U.S.C. 47123. <i>(Executive Order 13166)</i>
Color	Color of skin, including shade of skin within a racial group	Black, White, brown, yellow, etc.	
National Origin <i>(Limited English Proficiency)</i>	Place of birth. Citizenship is not a factor. <i>(Discrimination based on language or a person's accent is also covered)</i>	Mexican, Cuban, Japanese, Vietnamese, Chinese	
Sex	Gender. The sex of an individual. <i>Note: Sex under this program does not include sexual orientation.</i>	Women and Men	1973 Federal-Aid Highway Act; 49 U.S.C. 5332(b); 49 U.S.C. 47123.
Age	Persons of any age	21-year-old person	Age Discrimination Act of 1975 49 U.S.C. 5332(b); 49 U.S.C. 47123.
Disability	Physical or mental impairment, permanent or temporary, or perceived.	Blind, alcoholic, para-amputee, epileptic, diabetic, arthritic	Section 504 of the Rehabilitation Act of 1973; Americans with Disabilities Act of 1990
Religion (in the context of employment) <i>(Religion/ Creed in all aspects of any aviation or transit-related construction)</i>	An individual belonging to a religious group; or the perception, based on distinguishable characteristics that a person is a member of a religious group. In practice, actions taken as a result of the moral and ethical beliefs as to what is right and wrong, which are sincerely held with the strength of traditional religious views. <i>Note: Does not have to be associated with a recognized religious group or church; if an individual sincerely holds to the belief, it is a protected religious practice.</i>	Muslim, Christian, Sikh, Hindu, etc.	Title VII of the Civil Rights Act of 1964; 23 CFR 230; FHWA-1273 Required Contract Provisions. <i>(49 U.S.C. 5332(b); 49 U.S.C. 47123)</i>

(3) Pertinent Nondiscrimination Authorities

During the performance of this contract, the contractor, for itself, its assignees, and successors in interest agrees to comply with the following non-discrimination statutes and authorities, including, but not limited to:

- (a) Title VI of the Civil Rights Act of 1964 (42 U.S.C. § 2000d et seq., 78 stat. 252), (prohibits discrimination on the basis of race, color, national origin); and 49 CFR Part 21.

- (b) The Uniform Relocation Assistance and Real Property Acquisition Policies Act of 1970, (42 U.S.C. § 4601), (prohibits unfair treatment of persons displaced or whose property has been acquired because of Federal or Federal-aid programs and projects);
- (c) Federal-Aid Highway Act of 1973, (23 U.S.C. § 324 et seq.), (prohibits discrimination on the basis of sex);
- (d) Section 504 of the Rehabilitation Act of 1973, (29 U.S.C. § 794 et seq.), as amended, (prohibits discrimination on the basis of disability) and 49 CFR Part 27;
- (e) The Age Discrimination Act of 1975, as amended, (42 U.S.C. § 6101 et seq.), (prohibits discrimination on the basis of age);
- (f) Airport and Airway Improvement Act of 1982, (49 USC § 471, Section 47123), as amended, (prohibits discrimination based on race, creed, color, national origin, or sex);
- (g) The Civil Rights Restoration Act of 1987, (PL 100-209), (Broadened the scope, coverage and applicability of Title VI of the Civil Rights Act of 1964, The Age Discrimination Act of 1975 and Section 504 of the Rehabilitation Act of 1973, by expanding the definition of the terms "programs or activities" to include all of the programs or activities of the Federal-aid recipients, sub-recipients and contractors, whether such programs or activities are Federally funded or not);
- (h) Titles II and III of the Americans with Disabilities Act, which prohibit discrimination on the basis of disability in the operation of public entities, public and private transportation systems, places of public accommodation, and certain testing entities (42 U.S.C. §§ 12131-12189) as implemented by Department of Transportation regulations at 49 C.F.R. parts 37 and 38;
- (i) The Federal Aviation Administration's Nondiscrimination statute (49 U.S.C. § 47123) (prohibits discrimination on the basis of race, color, national origin, and sex);
- (j) Executive Order 12898, Federal Actions to Address Environmental Justice in Minority Populations and Low-Income Populations, which ensures Nondiscrimination against minority populations by discouraging programs, policies, and activities with disproportionately high and adverse human health or environmental effects on minority and low-income populations;
- (k) Executive Order 13166, Improving Access to Services for Persons with Limited English Proficiency, and resulting agency guidance, national origin discrimination includes discrimination because of Limited English proficiency (LEP). To ensure compliance with Title VI, you must take reasonable steps to ensure that LEP persons have meaningful access to your programs (70 Fed. Reg. at 74087 to 74100);
- (l) Title IX of the Education Amendments of 1972, as amended, which prohibits you from discriminating because of sex in education programs or activities (20 U.S.C. 1681 et seq).
- (m) Title VII of the Civil Rights Act of 1964 (42 U.S.C. § 2000e et seq., Pub. L. 88-352), (prohibits employment discrimination on the basis of race, color, religion, sex, or national origin).

(4) Additional Title VI Assurances

***The following Title VI Assurances (Appendices B, C and D) shall apply, as applicable*

- (a) Clauses for Deeds Transferring United States Property (1050.2A, Appendix B)

The following clauses will be included in deeds effecting or recording the transfer of real property, structures, or improvements thereon, or granting interest therein from the United States pursuant to the provisions of Assurance 4.

NOW, THEREFORE, the U.S. Department of Transportation as authorized by law and upon the condition that the North Carolina Department of Transportation (NCDOT) will accept title to the lands and maintain the project constructed thereon in accordance with the North Carolina General Assembly, the Regulations for the Administration of the Federal-Aid Highway Program, and the policies and procedures prescribed by the Federal Highway Administration of the U.S. Department of Transportation in accordance and in compliance with all requirements imposed by Title 49, Code of Federal Regulations, U.S. Department of Transportation, Subtitle A, Office of the Secretary, Part 21, Nondiscrimination in Federally-assisted programs of the U.S. Department of Transportation pertaining to and effectuating the provisions of Title VI of the Civil Rights Act of 1964 (78 Stat. 252; 42 U.S.C. § 2000d to 2000d-4), does hereby remise, release, quitclaim and convey unto the NCDOT all the right, title and interest of the U.S. Department of Transportation in and to said lands described in Exhibit A attached hereto and made a part hereof.

(HABENDUM CLAUSE)

TO HAVE AND TO HOLD said lands and interests therein unto the North Carolina Department of Transportation (NCDOT) and its successors forever, subject, however, to the covenants, conditions, restrictions and reservations herein contained as follows, which will remain in effect for the period during which the real property or structures are used for a purpose for which Federal financial assistance is extended or for another purpose involving the provision of similar services or benefits and will be binding on the NCDOT, its successors and assigns.

The NCDOT, in consideration of the conveyance of said lands and interests in lands, does hereby covenant and agree as a covenant running with the land for itself, its successors and assigns, that (1) no person will on the grounds of race, color, or national origin, be excluded from participation in, be denied the benefits of, or be otherwise subjected to discrimination with regard to any facility located wholly or in part on, over, or under such lands hereby conveyed [,] [and]* (2) that the NCDOT will use the lands and interests in lands and interests in lands so conveyed, in compliance with all requirements imposed by or pursuant to Title 49, Code of Federal Regulations, U.S. Department of Transportation, Subtitle A, Office of the Secretary, Part 21, Nondiscrimination in Federally-assisted programs of the U.S. Department of Transportation, Effectuation of Title VI of the Civil Rights Act of 1964, and as said Regulations and Acts may be amended [, and (3) that in the event of breach of any of the above-mentioned nondiscrimination conditions, the Department will have a right to enter or re-enter said lands and facilities on said land, and that above described land and facilities will thereon revert to and vest in and become the absolute property of the U.S. Department of Transportation and its assigns as such interest existed prior to this instruction].*

(*Reverter clause and related language to be used only when it is determined that such a clause is necessary in order to make clear the purpose of Title VI.)

(b) Clauses for Transfer of Real Property Acquired or Improved Under the Activity, Facility, or Program (1050.2A, Appendix C)

The following clauses will be included in deeds, licenses, leases, permits, or similar instruments entered into by the North Carolina Department of Transportation (NCDOT) pursuant to the provisions of Assurance 7(a):

1. The (grantee, lessee, permittee, etc. as appropriate) for himself/herself, his/her heirs, personal representatives, successors in interest, and assigns, as a part of the consideration hereof, does hereby covenant and agree [in the case of deeds and leases add "as a covenant running with the land"] that:
 - (i.) In the event facilities are constructed, maintained, or otherwise operated on the property described in this (deed, license, lease, permit, etc.) for a purpose for which a U.S. Department of Transportation activity, facility, or program is extended or for another purpose involving the provision of similar services or benefits, the (grantee, licensee, lessee, permittee, etc.) will maintain and operate such facilities and services in compliance with all requirements imposed by the Acts and Regulations (as may be amended) such that no person on the grounds of race, color, or national origin, will be excluded from participation in, denied the benefits of, or be otherwise subjected to discrimination in the use of said facilities.
2. With respect to licenses, leases, permits, etc., in the event of breach of any of the above Nondiscrimination covenants, the NCDOT will have the right to terminate the (lease, license, permit, etc.) and to enter, re-enter, and repossess said lands and facilities thereon, and hold the same as if the (lease, license, permit, etc.) had never been made or issued. *
3. With respect to a deed, in the event of breach of any of the above Nondiscrimination covenants, the NCDOT will have the right to enter or re-enter the lands and facilities thereon, and the above described lands and facilities will there upon revert to and vest in and become the absolute property of the NCDOT and its assigns. *

(*Reverter clause and related language to be used only when it is determined that such a clause is necessary to make clear the purpose of Title VI.)

(c) Clauses for Construction/Use/Access to Real Property Acquired Under the Activity, Facility or Program (1050.2A, Appendix D)

The following clauses will be included in deeds, licenses, permits, or similar instruments/ agreements entered into by the North Carolina Department of Transportation (NCDOT) pursuant to the provisions of Assurance 7(b):

1. The (grantee, licensee, permittee, etc., as appropriate) for himself/herself, his/her heirs, personal representatives, successors in interest, and assigns, as a part of the consideration hereof, does hereby covenant and agree (in the case of deeds and leases add, "as a covenant running with the land") that (1) no person on the ground of race, color, or national origin, will be excluded from participation in, denied the benefits of, or be otherwise subjected to discrimination in the use of said facilities, (2) that in the construction of any improvements on, over, or under such land, and the furnishing of services thereon, no person on the ground of race, color, or national origin, will be excluded from participation in, denied the benefits of, or otherwise be subjected to discrimination, (3) that the (grantee, licensee, lessee, permittee, etc.) will use the premises in compliance with all other requirements imposed by or pursuant to the Acts and Regulations, as amended, set forth in this Assurance.
2. With respect to (licenses, leases, permits, etc.), in the event of breach of any of the above Non-discrimination covenants, the NCDOT will have the right to terminate the (license, permit, etc., as appropriate) and to enter or re-enter and repossess said land and the facilities thereon, and hold the same as if said (license, permit, etc., as appropriate) had never been made or issued. *
3. With respect to deeds, in the event of breach of any of the above Nondiscrimination covenants, the NCDOT will there upon revert to and vest in and become the absolute property of the NCDOT and its assigns. *

(*Reverter clause and related language to be used only when it is determined that such a clause is necessary to make clear the purpose of Title VI.)

STANDARD SPECIAL PROVISION**ON-THE-JOB TRAINING**

(10-16-07) (Rev. 6-16-26)

Z-10

Description

The North Carolina Department of Transportation administers a custom version of the Federal On-the-Job Training (OJT) Program, commonly referred to as the Alternative OJT Program. All Contractors will be automatically placed in the Alternative OJT Program.

The Alternate OJT Program will allow a Contractor to train employees on Federal, State and privately funded projects located in North Carolina. However, priority shall be given to training employees on NCDOT Federal-Aid funded projects.

On the Job Training shall meet the requirements of 23 CFR 230.107 (b), 23 USC – Section 140, this special provision and the NCDOT On-the-Job Training Program Manual.

Minorities and Women

Developing, training and upgrading of minorities and women toward journeyman level status is a primary objective of this special provision. Accordingly, the Contractor shall make every effort to enroll minority and women as trainees to the extent that such persons are available within a reasonable area of recruitment. This training commitment is not intended, and shall not be used, to discriminate against any applicant for training, whether a member of a minority group or not.

Assigning Training Goals

The Department, through the OJT Program Unit, will assign annual training goals based on the Contractor's activity over the past three years' on federal projects with the Department. At the beginning of each year, all eligible Contractors will be contacted by the Department to determine the number of trainees that will be assigned for the upcoming calendar year. At that time, the Contractor shall enter into an agreement with the Department to implement a self-imposed on-the-job training program for the calendar year. This agreement will specify the annual training goals agreed upon by both parties. The number of training assignments may range from 1 to 15 per Contractor per calendar year, unless a higher number is agreed to by the Contractor. The Contractor shall sign an agreement committing to fulfill their annual goal for the year.

Training Classifications

The Contractor shall provide on-the-job training aimed at developing full journeyman level workers in the construction craft/operator positions.

The Department has established common training classifications and their respective training requirements that may be used by the Contractors. However, the classifications established are not all-inclusive. Where the training is oriented toward construction applications, training will be allowed in lower-level management positions such as office engineers and estimators. Contractors shall submit new classifications for specific job functions that their employees are performing.

The Department will review and recommend for acceptance to FHWA the new classifications proposed by contractors, if applicable. New classifications shall meet the following requirements:

Proposed training classifications are reasonable and realistic based on the job skill classification needs, and

The number of training hours specified in the training classification is consistent with common practices and provides enough time for the trainee to obtain journeyman level status.

The Contractor may allow trainees to be trained by a subcontractor provided that the Contractor retains primary responsibility for meeting the training and this special provision is made applicable to the subcontract. However, only the Contractor will receive credit towards the annual goal for the trainee.

Where feasible, 25 percent of trainees in each occupation shall be in their first year of training. The number of trainees shall be distributed among the work classifications on the basis of the Contractor's needs and the availability of journeymen in the various classifications within a reasonable area of recruitment.

No employee shall be employed as a trainee in any classification in which they have successfully completed a training course leading to journeyman level status or in which they have been employed as a journeyman.

Records and Reports

The Contractor shall maintain enrollment, monthly and completion reports documenting company compliance under these contract documents. These documents and any other information as requested shall be submitted to the OJT Program Manager.

Upon completion and graduation of the program, the Contractor shall provide each trainee with a certification Certificate showing the type and length of training satisfactorily completed.

Trainee Interviews

All trainees enrolled in the program will receive at minimum an initial and Trainee/Post graduate interview conducted by the OJT program staff.

Trainee Wages

Contractors shall compensate trainees on a graduating pay scale based upon a percentage of the prevailing minimum journeyman wages (Davis-Bacon Act). Minimum pay shall be as follows:

60 percent	of the journeyman wage for the first half of the training period
75 percent	of the journeyman wage for the third quarter of the training period
90 percent	of the journeyman wage for the last quarter of the training period

In no instance shall a trainee be paid less than the local minimum wage. The Contractor shall adhere to the minimum hourly wage rate that will satisfy both the NC Department of Labor (NCDOL) and the Department.

Achieving or Failing to Meet Training Goals

The Contractor will be credited for each trainee currently enrolled or becomes enrolled in an approved program and who receives training for at least 50 percent of the specific program requirement. Trainees will be allowed to be transferred between projects if required by the Contractor's scheduled workload to meet training goals.

If a Contractor fails to attain their training assignments for the calendar year, they may be taken off the NCDOT's Bidders List.

Measurement and Payment

No compensation will be made for providing required training in accordance with these contract documents.

WORK ZONE TRAFFIC CONTROL

Project Special Provisions

Table of Contents

Special Provision	Page
Work Zone Traffic Control for Interstate/Freeway Resurfacing	TC-2
Connected Lane Closure System	TC-16
Work Zone Digital Speed Limit Signs	TC-19
Work Zone Presence Lighting	TC-24
High Visibility Devices	TC-27



DocuSigned by:
Zachary T Clark
9C4DA7F17F6D420...
04/22/2026

TC-2

DN12225454

Haywood

WORK ZONE TRAFFIC CONTROL FOR INTERSTATE/FREEWAY RESURFACING

(2/17/2020) (Rev. 09/19/2025)

General Requirements

This Provision is intended for interstate / freeway resurfacing projects. In the event, the day and time restrictions allow for daytime work activities the Work Zone Presence Lighting and Sequential Flashing Lights are to be omitted during daylight hours. However, the Digital Speed Limit Signs and Connected Lane Closure Devices will be required at all times as described below.

Maintain traffic in accordance with Divisions 10, 11 and 12 of the *NCDOT Standard Specifications* and the following provisions:

Install Work Zone Advance Warning Signs in accordance with the attached drawing prior to beginning any other work.

When personnel and/or equipment are working within 10 feet of an open travel lane on a divided facility, close the nearest open travel lane using Standard Drawing 1101.02 of the *NCDOT Roadway Standard Drawings*.

When personnel and/or equipment are working within a lane of travel of a divided facility, close the lane using Standard Drawing 1101.02 of the *NCDOT Roadway Standard Drawings* or as directed by the Engineer.

Conduct the work so that all personnel and/or equipment remain within the closed travel lane. Perform work only when weather and visibility conditions allow safe operations as directed by the Engineer.

Remove lane closure devices from the lane when work is not being performed behind the lane closure or when a lane closure is no longer needed or as directed by the Engineer.

1. Time Restrictions for Lane Closure and Road Closure Activities

All lane closure and road closure activities shall be performed in compliance with the day and time restrictions listed and defined in this Contract.

Any activities performed outside of these requirements will be subject to liquidated damages unless approved by the Engineer prior to beginning the activity.

TC-3

DN12225454

Haywood

The Contractor may place/pre-stage all required signs and traffic control devices necessary for lane closures prior to the closure time as approved by the Engineer. However, flashing arrow boards and changeable message signs shall not indicate lane closure information until 30 minutes or less prior to the installation of the lane closure taper. Allowable pre-staging times are 1 hour for a single lane closure and 2 hours for double and triple lane closures. The travel lane(s) are to be closed at the prescribed times defined in this Contract. When available, law enforcement should be onsite to shadow workers during pre-staging activities.

For removal, the lane(s) must be reopened in compliance with the times defined in this Contract. It is acceptable to remove the signs and traffic control devices from the shoulder/staging area after the lane(s) are reopened to traffic. All electronic lane closure messages and flashing arrow displays shall be off once lanes are opened. When available, law enforcement should remain on the project while workers remove and secure their signs and devices.

2. Work Zone Speed Limits and Digital Speed Limit Signs (DSLS)

All speed limits are the sole authority of the NCDOT. An ordinance signed by the State Traffic Engineer is required for all speed limits in order to have a lawfully enforceable speed limit. No speed limit messages/signs shall be installed prior to receiving a signed ordinance.

The Regional Traffic Engineering Office and the Division Construction Engineer in coordination with the Work Zone Traffic Control Section will provide all work zone speed limit recommendations based on activities and conditions.

When lane closures are in effect, implement a Work Zone Variable Speed Limit Reduction as stated in the ordinance and in accordance with the attached provision and drawing.

Use Digital Speed Limit Signs (DSLS) to display the work zone speed limit as shown in the attached special provision and drawing. The speed limit shall be continuously displayed on the digital speed limit signs.

The Contractor will be responsible for coordinating with the Engineer when the work zone speed limits are to be changed and will have to seek approval by the Engineer before the speed limit is changed.

When the variable speed limit reductions are in effect, cover or remove any existing speed limit signs located within the active work area that conflict with the variable speed limit reduction.

TC-4

DN12225454

Haywood

The speed limit shall be returned to the existing speed limit when the lane closure is removed and traffic is returned to the existing pattern.

3. Connected Lane Closure Devices

Furnish and install Connected Lane Closure Devices that transmit the location of the lane closure to navigational companies and the Statewide Transportation Operations Center (STOC).

4. Work Zone Presence Lighting and Sequential Flashing Warning Lights

Provide the following for nighttime work activities:

A. Furnish and install Work Zone Presence Lighting to supplement the Contractor's portable construction and equipment lighting for the purpose of alerting motorists to the existence of an active work zone and to encourage compliance with the reduced work zone speed limit. See attached special provision.

B. Furnish and install Sequential Flashing Warning Lights on drums used for merging tapers to assist motorists in determining which direction to merge and to decrease late lane merging. Refer to Section 1140 of the *NCDOT Standard Specifications*.

5. Law Enforcement

Use two (2) off duty, uniformed law enforcement officers and official law enforcement vehicles, equipped with blue lights during lane closure operations and one (1) additional law enforcement officer for each ramp/loop closure when both operations occur simultaneously.

Use law enforcement officers to assist in the shadowing of workers during the installation and during the removal of lane closures.

Law enforcement vehicles shall not be parked within the buffer space or be used to block an active travel lane at any time, including while installing or removing lane closure tapers. When possible, position one law enforcement officer downstream of the other to conduct enforcement operations. When space is confined, conduct enforcement outside of the lane closure area.

Temporary Traffic Control (TTC)

Refer to Standard Drawing No. 1101.02, 1101.11, 1110.01, 1110.02, 1115.01, 1130.01, 1135.01, 1165.01, and 1180.01 of the *NCDOT Roadway Standard Drawings* when closing a lane of travel

TC-5

DN12225454

Haywood

in a stationary work zone for items such as milling, paving, diamond grinding concrete pavements, minor bridge operations, and approach slab rehabilitation.

Drums are recommended for all lane closure operations occurring at night. However, if skinny drums are used at night, they shall be placed every 80' in the tangent sections of lane closure operations. Skinny drums shall not be used for upstream or shifting tapers.

When covering any signs, use an opaque material that prevents reading of the sign at night by a driver using high beam headlights. Use material which does not damage the sign sheeting. Adhesives of any kind, including tape, shall not be applied to the sign face.

Refer to Roadway Standard Drawing No. 1101.02, Sheets 10 and 11, of the *NCDOT Roadway Standard Drawings* for diamond grinding, milling and/or paving of ramps unless otherwise approved to be closed by the Engineer. If approved, see attached drawing for typical placement of devices and signing for the detour route. All items shall be compensated for based on the unit bid price for the respective item.

Refer to Roadway Standard Drawing No. 1101.03, Sheet 7, of the *NCDOT Roadway Standard Drawings* for a closure of the interstate/freeway with traffic detoured via interchange ramps for items such as minor bridge and approach slab rehabilitation. Use flaggers or law enforcement to direct traffic at ramp terminals as directed by the Engineer.

Refer to Roadway Standard Drawing No. 1101.02, Sheet 15 or 16, of the *NCDOT Roadway Standard Drawings* for utilizing a moving operation for such items as pavement marking and marker placement. A minimum speed of 3 mph shall be maintained at all times with no stops that narrow or close a lane of travel. If the moving operation is progressing slower than 3 mph at any time, install a lane closure. All traffic control devices for this operation are considered incidental to the pay items for pavement markings and markers.

Traffic Operations

1. Project Requirements

Failure to comply with the following requirements will result in a suspension of all other operations:

- A. Before working on ANY MAP, the Contractor shall submit a written construction sequence for traffic control and construction lighting for ALL MAPS to the Engineer at the first pre-construction meeting and the sequence must be approved before closing a lane of traffic.

TC-6

DN12225454

Haywood

- B. The standard active work area is 2 miles. This is defined as the distance of Resurfacing Operations taking place in a single work period. However, the maximum allowed lane closure distance is 5 miles. Approval by the Engineer is required before closing more than 2 miles of Interstate to ensure the Contractor has the equipment and labor force to actively pursue the work.
- C. Notify the Engineer 15 consecutive calendar days before resurfacing a bridge or its approaches. Patch and make repairs to bridge surface and its approaches before resurfacing occurs. Coordinate all operations on the bridge and its approaches with the Engineer.
- D. Notify the Engineer 48 hours before resurfacing the areas of existing pavement that require patching. Patch these areas before resurfacing occurs. Allow full depth asphalt patching to cool to the point of supporting traffic without displacement or rutting before reopening closed lane. Coordinate the resurfacing operations of the patched areas with the Engineer.
- E. Notify the Engineer 48 hours before milling or resurfacing will interfere with the existing Signal Loops. Loops may need to be placed in milled surface before resurfacing occurs. Coordinate all signal loop operations with the Engineer.
- F. Obtain written approval of the Engineer before working in more than one location or setting up additional lane closures.
- G. The Contractor on this and any adjacent projects, or subcontractors working within this project shall coordinate lane closure location, type, and direction with the Engineer to best maintain lane continuity through the limits of this and adjacent projects.
- H. Operate equipment and conduct operations in the same direction as the flow of traffic. Maintain vehicular access in accordance with Article 1101-05 of the *NCDOT Standard Specifications*.
- I. Provide appropriate construction lighting in accordance with Section 1413 of the *NCDOT Standard Specifications*.
- J. The Contractor shall diamond grind, mill, and pave lanes in an order such that water shall not accumulate.

2. Paving Lift Requirements and Time Limitations

Failure to comply with the following requirements will result in a suspension of all other operations until all lanes of traffic are brought to the same station and elevation:

Paving Overlays and Lifts up to 3"

- A. For surface course paving lifts of 2" or less, the Contractor shall conduct his paving operations such that the following conditions are met.

Once paving begins in any lane, the Contractor will be permitted to pave as far as the work operations allow (up to 5 miles) for the initial paving period. In the next days' paving operation, not to exceed 72 hours later, bring the adjacent lane to the same station and elevation. At the end of the work period, any uneven lane conditions shall be signed with an "UNEVEN PAVEMENT/NEXT XX MILES" on the portable changeable message signs and portable "UNEVEN PAVEMENT" signs (dual mounted) 1,000' in advance of the uneven pavement and every ½ miles thereafter along the uneven portion of roadway. Once mitigated, all portable "UNEVEN PAVEMENT" signs shall be removed.

For Open Graded Surface Mixes, "UNEVEN PAVEMENT" signs are not required.

- B. For 3" surface course mixes, place in two paving lifts of 1 ½" each unless directed otherwise by the Engineer. Conditions for uneven travel lanes same as described above.

Paving Lifts Greater than 3"

For all other paving lifts greater than 3", bring all newly resurfaced lanes to the same station and elevation by the end of each work period unless the Contractor utilizes the notched wedge paving methods as described below:

- A. Any paving lift greater than 3" shall be mitigated by having an approved wedge apparatus on the paver that shapes the edge 1" vertically and the remaining at a maximum slope steepness of 2:1. The maximum paving lift allowed to use this method is 3".
- B. At the end of the work period, the Contractor shall place portable "UNEVEN PAVEMENT" signs in advance of the uneven pavement and spaced every ½ mile along the section of uneven pavement. Once mitigated, all portable "UNEVEN PAVEMENT" signs shall be removed.

TC-8

DN12225454

Haywood

- C. In the next day's paving operation and not to exceed 72 hours later, the Contractor shall bring up the adjacent lane to the same station and elevation before any further paving takes place on the project.

Milling Operations (Does Not Apply to Fine Milling)

Conduct milling operations so that any milled pavement is paved back by the end of each work period.

A milled/grooved surface shall not be re-opened to traffic except in cases where inclement weather or mechanical failure prevents the paving back of the lane by the end of the work period.

If milled areas are not paved back within the same work period due to inclement weather or mechanical failure, the Contractor is to furnish and install portable signs to warn drivers of the conditions. The signs include "Grooved Pavement" (W8-15) w/ Motorcycle Plaque mounted below, and "Uneven Lanes" (W8-11). These are to be dual indicated where lateral clearance can be obtained within the median areas. Install the "Grooved Pavement" (W8-15) w/ Motorcycle Plaque 1500' in advance of the milled area. Install the "Uneven Lanes" (W8-11) 500' in advance of the milled area. Alternate these signs every ½ mile. Once mitigated, all portable signs are to be removed.

Slope the pavement at the beginning and end of the daily milling operation as directed by the Engineer. Sweep and remove all milled material from the roadway as soon as the daily milling operation is completed. Remove any existing pavement adjacent to the milled area that has been damaged and replace it with patch material as directed by the Engineer.

Fine Milling / Microsurfacing Operations (Depths less than 1")

For fine milling operations less than 1", paving is not required in the same work period. The paving of the fine milled area is to be conducted within the next work period and not to exceed 72 hours later. No advance warning signs are needed for the conditions. However, pavement markings are required by the end of each work period.

3. Pavement Markings and Markers

Review and record the existing pavement markings and markers before obliteration. Re-establish the new pavement markings and markers using the record of existing markings in conjunction with the contract. Unless otherwise directed by the Engineer, new pavement markings and markers not meeting the current standards should be updated as specified in the contract. Submit the record of

TC-9

DN12225454

Haywood

the existing pavement markings seven calendar days before the obliteration of any pavement markings.

Obliterated pavement markings shall be replaced by the end of each work period. Interim paint may be used to comply with time limitations if final pavement markings cannot be placed except for milled surfaces or diamond ground surfaces. Final markings shall be placed using the record of existing markings within 30 days in accordance with Section 1205-4 and Section 1205-5. For milled surfaces, temporary pavement markings shall be used in accordance with Section 1205-8(C). There will be no direct payment for interim paint. Temporary paint will be paid for at the contract unit price.

For concrete surfaces that have been diamond ground as a surface treatment, 4" temporary paint shall be used in accordance with Section 1205-8(C). Upon completion of all diamond grinding operations, 4" line removal shall be used to remove 100% of the 4" temporary paint on the final concrete surface by grinding method only. Use an acceptable method to grind ridges smooth only where pavement markings will be installed prior to placing final pavement marking material. This method shall also be used in the area of the black contrast for surface preparation. Payment for line removal will be made in accordance with Section 1205-10.

For project winterization, install temporary paint markings in accordance with Section 1205-8(C) of the *NCDOT Standard Specifications*. Use 4" lane, edge, and center lines and 8" gore lines. Compensation for this work shall be made in accordance with Section 1205-10 except that no payment will be made if paving is completed more than 30 days before the written notification by the Department that winterization is required.

4. Work Zone Signing

A. Description

Install advance/general warning work zone signs according to the attached drawings prior to beginning work.

For paving overlays of 3" or greater that create a drop-off adjacent to the median shoulder, install "LOW/SOFT SHOULDER" (SP 13107) signs on the median shoulder. Place initially at the construction limits, and then space 1 mile thereafter. No signing required for the outside shoulder.

Install and maintain signing in accordance with Divisions 11 and 12 of the *NCDOT Standard Specifications*.

B. Installation

All stationary Work Zone Advance/General Warning signs require notification to existing Utility owners per Article 105-8 of the *NCDOT Standard Specifications* and within 3 to 12 full working days prior to installation.

Install all Work Zone Advance/General Warning signs before beginning work on a particular map. If signs are installed more than seven (7) calendar days prior to the beginning of work on a particular map, cover the signs until the work begins. Install each Work Zone Advance/General Warning sign separately and not on the same post or stand with any other sign except where an advisory speed plate or directional arrow is used.

All sign locations to be verified by the Engineer prior to installation. Once the signs have been installed and accepted, any sign relocations requested by the Department will be compensated in accordance with Article 104-7. Any additional signs other than the ones required in this provision or attached drawings will be compensated in accordance with Article 104-7.

If there is a period of construction inactivity longer than 14 calendar days, remove or cover Work Zone Advance/General Warning signs. Uncover Work Zone Advance/General Warning signs no more than 7 calendar days before work resumes.

All other operations may be suspended upon failure to comply with the above requirements. Such suspended operations would not be resumed until the above requirements are fulfilled.

C. Sign Removal

Once Maps on the project are substantially completed, it is acceptable to remove the stationary work zone signs on those Maps in lieu of waiting until all of the Maps are completed on the project. A Map is substantially complete when the resurfacing operations are completed and the shoulders are brought up to the same elevation as the proposed pavement and when temporary pavement markings (paint) are installed along the centerline and edge lines as well as the ramps and loops. The final pavement markings (thermoplastic or polyurea) and/or markers do not have to be installed for the Map to be considered substantially complete. Final pavement markings and markers are installed with portable signing and changeable message signs according to Roadway Standard Drawing 1101.02, Sheet 16. Any remaining punch list items requiring traffic control are to be completed using

TC-11

DN12225454

Haywood

portable work zone signing with compensation covered in the contract unit price for the required traffic control items.

Stationary Work Zone Sign removal is a condition of final project acceptance.

D. Lane Closure Work Zone Signs

Install any required lane closure signing needed during the life of the project in accordance with Standard Drawing No. 1101.02, 1101.11, and 1110.02 of the *NCDOT Roadway Standard Drawings*.

Measurement and Payment

The lane closure distance is measured from the end of the merge taper where traffic is completely in the remaining open lane(s) to the last channelizing device closing the lane. For multiple lane closures, the lane closure distance is measured from the end of the first merge taper to the last channelizing device closing the lanes.

Work Zone Signs (Stationary) will be measured and paid in accordance with Section 1110-4 of the *Standard Specifications*.

Single Lane Closure will be measured and paid as the actual number of single stationary lane closures satisfactorily installed for required operations as shown in Roadway Standard Drawing 1101.02, Sheets 4, 5, 6, 10 & 11. All labor, traffic control devices, and signing for *Single Lane Closure*, up to 5 miles, as shown in these Roadway Standard Drawings are paid under this item.

Double Lane Closure will be measured and paid as the actual number of double stationary lane closures satisfactorily installed for paving and all other required operations as shown in Roadway Standard Drawing 1101.02, Sheets 8, 10 & 11. All labor, traffic control devices, and signing for *Double Lane Closure*, as shown in these Roadway Standard Drawings are paid under this item. In the event, separate double lane closures are necessary in the same direction as the work operation and the closures are at least 2 miles apart, the Contractor will be paid for each double lane closure.

Triple Lane Closure will be measured and paid as the actual number of triple stationary lane closures satisfactorily installed for paving and all other required operations as shown in Roadway Standard Drawing 1101.02, Sheets 9, 10 & 11. All labor, traffic control devices, and signing for *Triple Lane Closure* as defined above are paid under this item. In the event, separate triple lane closures are necessary in the same direction as the work operation and the closures are at least 2 miles apart, the Contractor will be paid for each triple lane closure.

TC-12

DN12225454

Haywood

Ramp/Loop Traffic Control will be measured and paid as the actual number of traffic control set ups satisfactorily installed at each ramp and loop. This includes set-ups on multiple lane ramps and loops. All labor, traffic control devices, and signing for *Ramp/Loop Traffic Control* are paid under this item.

Ramp/Loop Closure will be measured and paid as the actual number of total ramp/loop closures and detours satisfactorily installed for ramp/loop paving and all other required operations, as shown on Roadway Standard Drawing 1101.02, Sheets 12 & 13, and the Short Term Closure and Detour of Interstate/Freeway Ramps detail drawing. All labor, traffic control devices and signing required for re-routing traffic as shown on the Roadway Standard Drawing and the Short Term Closure and Detour of Interstate/Freeway Ramps detail drawing are paid under this item. In the event two separate ramps are closed at the same time, they will be measured individually and paid on a per each basis.

Paint Pavement Marking Lines, Paint Pavement Marking Symbols, and Removal of Pavement Marking Lines will be measured and paid in accordance with Section 1205-10 of the *Standard Specifications*.

Law Enforcement will be measured and paid in accordance with Section 1190-3 of the *Standard Specifications*.

Sequential Flashing Warning Lights will be measured and paid in accordance with Section 1140-5 of the *Standard Specifications*.

Digital Speed Limit Signs, Connected Lane Closure Devices, and Work Zone Presence Lighting are paid separately in accordance with their respective special provisions.

TC-13

DN12225454

Haywood

Payment will be made under:

Pay Item	Pay Unit
Work Zone Signs (Stationary)	SF
Single Lane Closure	EA
Double Lane Closure	EA
Triple Lane Closure	EA
Ramp/Loop Traffic Control	EA
Ramp/Loop Closures	EA
Paint Pavement Marking Lines (__”)	LF
Paint Pavement Marking Symbols	EA
Removal of Pavement Marking Lines (__”)	LF
Law Enforcement	HR
Sequential Flashing Warning Lights	EA

STATIONARY ADVANCE WARNING SIGNS FOR INTERSTATE / FREEWAY RESURFACING PROJECTS

DIVIDED MEDIANS WITH WIDTHS 46' OR GREATER

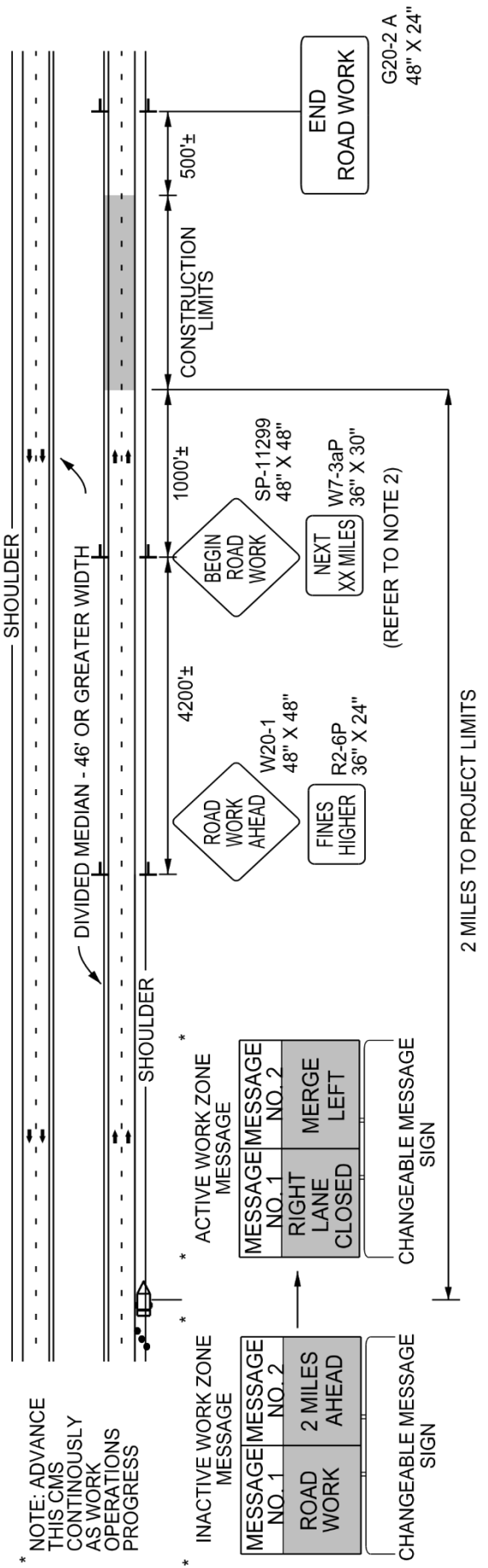

DIVIDED MEDIANS WITH WIDTHS LESS THAN 46' OR WITH PERMANENT MEDIAN BARRIER

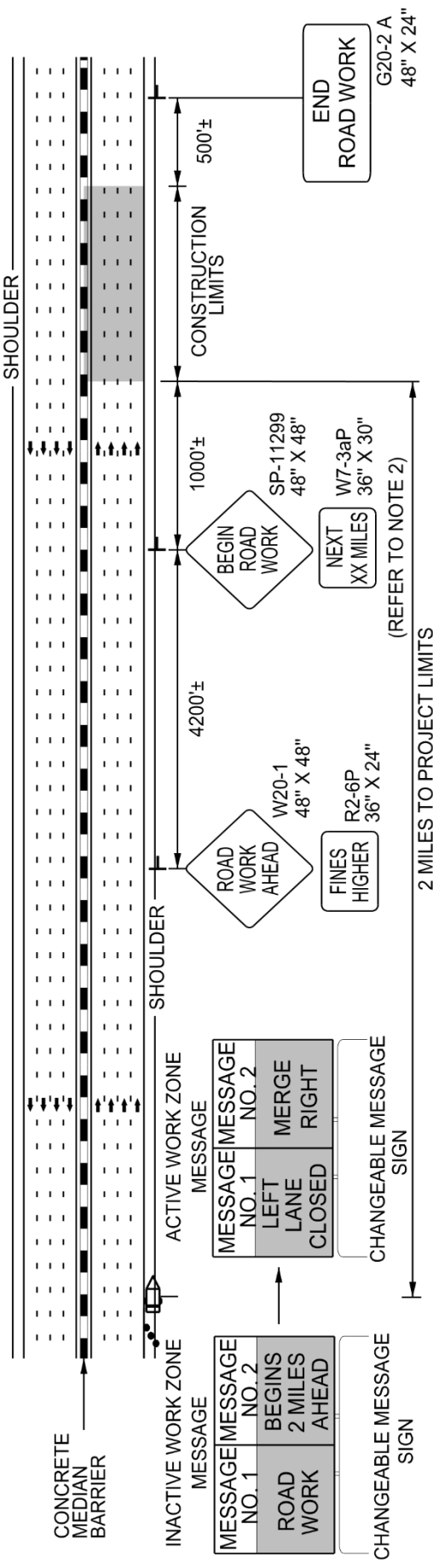

LEGEND

▲ DIRECTION OF TRAFFIC FLOW

● TRAFFIC DRUM

◁ CHANGEABLE MESSAGE SIGN (CMS)

⊥ STATIONARY SIGN

NOTES

- THIS DRAWING IS TO BE USED IN CONJUNCTION WITH THE WORK ZONE VARIABLE SPEED LIMIT USING DIGITAL SPEED LIMIT SIGNS FOR INTERSTATE/FREEWAY RESURFACING PROJECTS DETAIL.
- FOR SIGN W7-3aP, ROUND TO THE NEAREST MILE.
- FOR ENTRANCE AND EXIT RAMP, REFER TO RSD 1101.01, SHEET 1, DETAIL B & C.
- FOR ADDITIONAL NOTES, REFER TO RSD 1101.01, SHEET 1.

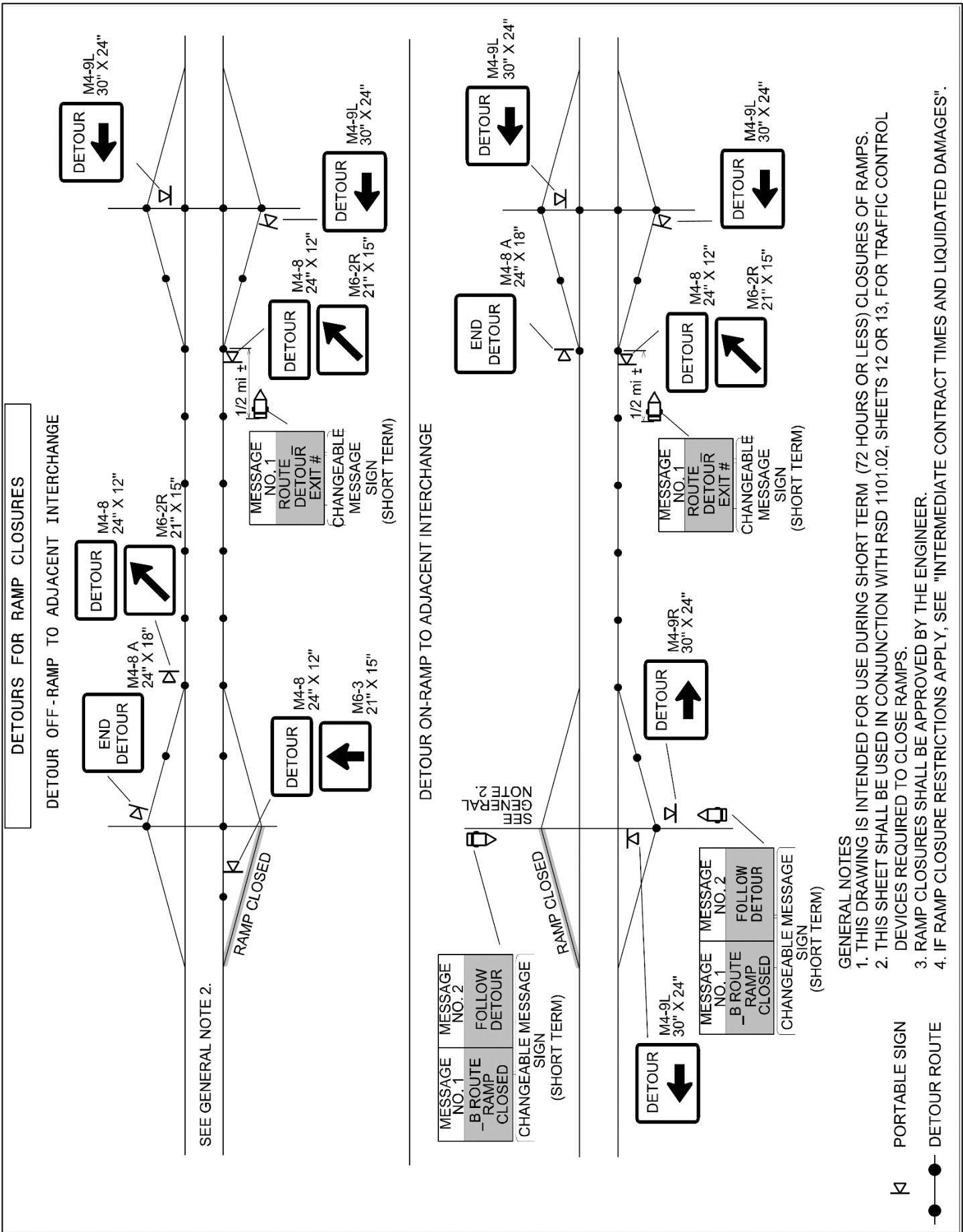

CONNECTED LANE CLOSURE SYSTEM

(10/29/2018) (Rev. 2/17/2026)

Description

Furnish, install, operate, maintain, relocate, and remove Connected Lane Closure Systems (CLCS) for lane closures on multi-lane roadways with posted speed limits of 55 mph and greater. The purpose of CLCS is to transmit real-time information of active lane closures for use by the State Transportation Operations Center (STOC), Regional Transportation Management Centers (TMCs), and traveler information systems; and for third party vendors (Mapping, Navigation, Connected Vehicles, etc.) to identify and provide advanced notification of active lane closures to approaching motorists.

Materials

The CLCS shall be designed and built to transmit the real-time location and direction of the lane closure. The information transmitted shall conform to the current version of the USDOT's Work Zone Data Exchange (WZDx) specification and be made available to NCDOT approved consumers of this data. More information about the WZDx specification can be found at (<https://www.transportation.gov/av/data/wzdx>)

The connected lane closure devices shall be capable of wireless communication.

The initial connected device representing the START location shall be designed and attached to the flashing arrow board in such a manner that it is only activated when either the left or right arrows are displayed, not when the flashing arrow board is operated in caution mode. The connected device shall no longer transmit location information when the flashing arrow board is turned off or changed to caution mode. The device shall have a visual indicator (e.g. an illuminated light, either steady burn or flash) to allow clear, visual proof the device is powered on, has established communication and is transmitting. The visual indicator shall not be located such that it potentially creates confusion for the motorists.

A second connected device representing the END location shall be installed on a crashworthy traffic control device. It shall have an easily accessible power switch and a small status indicator light mounted such that it is visible when passing by in a vehicle at operating speed. When switched to the ON position, the light shall indicate the device has established communication and is transmitting. The light may be either steady burn or flashing and shall not exceed one (1) inch in diameter. This second connected device representing the END location may be created virtually by a connected flashing arrow board.

TC-17

DN12225454

Haywood

The devices shall have sufficient battery life to maintain operation for the duration of the lane closure or can be recharged without deactivating the device or impacting the lane closure information transmitted to the external parties. All costs associated with charging are incidental and shall be included in the cost of the system.

Construction Methods

CLCS shall be used on all lane closures on multi-lane roadways with posted speed limits of 55 mph and greater throughout the duration of the project.

A START and END location shall be established by the installed system per grouping of lane closures (single, double, or triple); one attached and wired into the flashing arrow board at the beginning of the first taper. The other at the last traffic control device at the end of the lane closure(s) if the END location cannot be created virtually. Supplemental flashing arrow boards in advance of the first lane closure taper or flashing arrow boards in subsequent lane closures (for double and triple lane closures) shall not transmit location information if equipped with connected devices. Subsequent lane closures occurring downstream of where all lanes have been reopened or lane closures in the opposite direction of travel will require additional connected devices.

The second connected lane closure device shall be manually turned ON and OFF by crews installing and removing the lane closure unless the device can be controlled or virtually created by the initial connected device. The unit shall be turned ON immediately upon installation of the lane closure and turned OFF immediately upon removal of the lane closure.

When the lane closure is removed, the flashing arrow board shall be turned off or changed to caution mode, and the connected device shall automatically turn off simultaneously and shall no longer transmit location information. Turning the device away from traffic or moving the device to a staging area with the arrow board in arrow mode is not acceptable.

The CLCS shall run continuously during any active lane closure for the duration of the contract. Once installed, the Contractor shall verify that the connected lane closure devices are transmitting information prior to leaving the device unattended and re-verify transmission every 72 hours for long-term installations.

Technical Requirements

The GPS within the connected devices shall have a horizontal accuracy of 10 feet, 95% of the time.

TC-18

DN12225454

Haywood

The system shall send real-time alerts to designated NCDOT personnel when the flashing arrow mode or direction is changed. The alert shall be within 5 minutes of the actual change.

The connected device shall transmit a Connected Work Zone (CWZ) Device Feed in compliance with the Work Zone Data Exchange (WZDx) specification (WZDx Specification (Field Device) / Connected Work Zone Specification (CWZ)). The feed shall be transmitted within five (5) minutes of initiation and updated every fifteen (15) minutes to the central server.

All required properties shall be transmitted. In addition, the following properties are also require:

- Road Direction
- Road Name
- Status Messages
- Is in Transport Position

More information about the WZDx specification can be found at <https://www.transportation.gov/av/data/wzdx>.

The Contractor shall provide multiple logins to a secured server (e.g. vendor dashboard) that provides real-time and historic status. The status must be exportable, within 24 hours, in .csv or .xls/.xlsx format and include data for date, device name, flashing arrow mode, communication status, road name, road direction, battery voltage, time on, time off, and GPS coordinates. The historic logged information shall be available to CLCS users 24/7/365 during the length of the entire construction phase. All logged information from the project shall be retained by the Contractor and be available to the NCDOT for at least three (3) years after the contract ends.

The battery voltage shall be collected at least once an hour. The information shall be stored and available for troubleshooting. To prevent communication loss, the system shall transmit an alert via E-mail or SMS to designated personnel if the battery voltage of a device is under a specified threshold.

The CLCS shall provide an immediate electronic alert (e.g. via E-mail or SMS) to the Traffic Control Supervisor or other designated individual if a device is not transmitting its position for a period of 30 minutes or more.

The outputs from the connected device on the arrow board and the downstream connected (or virtual) device at the end of the lane closure shall be easily identifiable as a single system, either by sequential device IDs, identical project names, or other method as approved by the Engineer. Additional pairs on the project shall have unique identifiable information such that it is not confused with another project system.

TC-19

DN12225454

Haywood

Measurement and Payment

Connected Lane Closure System will be measured and paid as the maximum number of connected systems acceptably placed and in use at any one time during the life of the project. Each lane closure system may be satisfied by one of the following:

- Two (2) connected lane closure devices; one connected to the flashing arrow board and the other on a crashworthy device at the downstream end of the lane closure.
- One (1) connected lane closure device connected to the flashing arrow board that can generate a virtual END location with 10' accuracy.

All devices for each system must be functioning properly to receive payment for the system. No payment will be made for a system until all devices are satisfactorily installed and operational at the device and on the vendors dashboard. A copy of the device status reporting should be provided by the Contractor every 2 weeks.

The price for each connected lane closure system will cover all material, labor, maintenance, relocation, removal, and communication costs required for the duration of the project.

Flashing arrow boards and crashworthy devices (such as drums) used to mount the downstream connected lane closure device are paid separately elsewhere in this Contract.

Pay Item	Pay Unit
Connected Lane Closure System	Each

WORK ZONE DIGITAL SPEED LIMIT SIGNS

(5/10/2021) (Rev. 12/16/2025)

Description

Furnish and install Work Zone Digital Speed Limit Signs as indicated in the plans or as directed by the Engineer. Work Zone Digital Speed Limit Signs are regulatory speed limit signs with LED displays for the speed limit numbers.

Materials

Digital Speed Limit Signs shall be a minimum 36 inches wide x 48 inches high. The speed limit sign (R2-1) shall be black on white with high intensity white prismatic sheeting.

The Digital Speed Limit Sign shall be mounted such that the bottom of the sign is 7 feet above roadway.

TC-20

DN12225454

Haywood

The LED panel shall be a minimum of 28 inches wide x 18 inches high. The display on the LED panel shall be amber or white.

The LED numbers shall have a minimum 5 wide by 7 high pixel array with a minimum height of 18 inches.

The LED panel shall have auto brightness/dimming capability.

The black on orange G20-5aP WORK ZONE sign shall be mounted above the speed limit sign. It shall be 36 inches wide x 24 inches high with high intensity prismatic orange sheeting.

The black on white R2-6bP \$250 FINE sign shall be mounted below the speed limit sign. It shall be 36 inches wide x 24 inches high with high intensity prismatic white sheeting.

All digital speed limit systems shall have operational software and wireless communications that allows for remote operation and data monitoring. It shall be configured to allow access by the Engineer or their designee to change each sign independently or change the speed limit on all signs at once from a PC, tablet or cellular phone application.

The Work Zone Digital Speed Limit systems shall have flashing beacons. The beacons are to be a minimum of 8 inch diameter LED circular yellow. They shall be mounted above and below the sign assemblies and are to be centered. The beacons shall alternately flash at rates not less than 50 or more than 60 times per minute.

The flashing beacons shall be mounted in such a manner that the \$250 FINE sign is not obscured when in operation.

Digital Speed Limit Signs may be trailer mounted or stationary mounted. The unit shall be solar powered and operate continuously. It shall be supplemented with a battery backup system which includes a 110/120 VAC powered on-board charging system.

The batteries, when fully charged, shall be capable of powering the display for 20 continuous days with no solar power. The unit shall be capable of being powered by standard 110/120 VAC power source.

Store the battery bank and charging system in a locked, weather and vandal resistant box.

All Work Zone Digital Speed Limit Sign equipment shall be on the NCDOT Approved Products List.

Digital Speed Limit Displays

The speed limit shall be continuously displayed on the signs. All stationary speed limit signs shall be covered when Digital Speed Limit systems are in operation.

TC-21

DN12225454

Haywood

Displaying Reduced Speed Limits

The Digital Speed Limit systems shall have beacons activated when the work zone speed limit is reduced. Otherwise, the beacons are to remain off.

Displaying Existing Speed Limits

When the existing speed limit is displayed on the Digital Speed Limit Signs, the beacons are to remain off.

Other Construction Methods

The speed limits are the sole authority of the NCDOT. An ordinance signed by the State Traffic Engineer is required for all speed limits in order to have a lawfully enforceable speed limit.

The Regional Traffic Engineering Office and the Division Construction Engineer in coordination with the Work Zone Traffic Control Section will provide all work zone speed limit recommendations based on activities and conditions.

The Contractor will be responsible for coordinating with the Engineer when the work zone speed limits are to be changed and will have to seek approval by the Engineer or their designee before the speed limit is changed.

Whenever possible, each trailer mounted unit shall be placed on the paved shoulder and shall have the capability of being leveled.

Install stationary mounted advance warning signs WORK ZONE, VARIABLE SPEED ZONE AHEAD, and \$250 FINE according to the attached detail.

Measurement and Payment

Work Zone Digital Speed Limit Signs will be measured and paid as the maximum number of Work Zone Digital Speed Limit Signs satisfactorily installed according to the attached detail and properly functioning at any one time during the life of the project.

This includes all materials and labor to install, maintain and remove all the Work Zone Digital Speed Limit Signs.

Stationary mounted advance warning signs installed according to the attached detail are measured and paid separately in accordance with Article 1110-4 of the Standard Specifications.

Pay Item

Work Zone Digital Speed Limit Signs

Pay Unit

Each

TC-24

DN12225454

Haywood

WORK ZONE PRESENCE LIGHTING

(10/14/19) (Rev. 5/10/2021)

Description

Furnish and install Work Zone Presence Lighting during nightly lane closures on multilane roadways with speed limits of 55 mph or greater.

Materials

Anti-glare lighting systems are required. Work Zone Presence Lighting shall be installed in accordance with the attached detail and the Manufacturer's recommendations.

Supply a power source for each light to provide the light output as described in the chart below.

Each light unit shall be capable of providing a minimum of 14,000 lumens illuminating a minimum area of approximately 3,000 square feet. The light shall be capable of being elevated to a height of 14 feet above the pavement.

Each light unit support base or mounting stand shall have the capability of being leveled such that the light mast is plumb.

Provide Work Zone Presence Lighting listed on the NCDOT Approved Products List.

Construction Methods

Work Zone Presence Lighting is permitted to be prestaged (up to 1 hour prior for single lane closures and up to 2 hours prior for double or triple lane closures) along with other traffic control devices or installed within 1 hour after the necessary traffic control has been installed for the lane closure(s). At the end of the work night, the Work Zone Presence Lighting shall be removed within 1 hour before or after the lane closure(s) is removed.

Whenever possible, each light unit shall be placed on the outside paved shoulder, a minimum of 4 feet from the travel lane and spaced according to the chart below based on the amount of light output for each unit.

Work Zone Presence Lighting is permitted to supplement the Portable Construction Lighting inside the lane closure. At no time shall Work Zone Presence Lighting be used in lieu of Portable Construction Lighting when required.

If there is sufficient existing overhead lighting, Work Zone Presence Lighting may be eliminated as directed by the Engineer.

TC-25

DN12225454

Haywood

Lighting Unit Installation Requirements

The lighting units shall be installed in advance of the lane closure as shown on the attached detail and spaced according to the chart below:

Light Output (Lumens)	Illuminated Fixture Area (Sq. Ft.)	AREA 1		AREA 2	
		# of Lights	Spacing*	# of Lights	Spacing*
14,000 - 35,000	4	6	640' (16 skips)	8	480' (12 skips)
35,001 - 59,999	5	5	800' (20 skips)	6	640' (16 skips)
60,000+	6+	4	1,000' (25 skips)	5	800' (20 skips)

*Skips refer to traditional 10' pavement marking lines with 30' gaps.

Area 1: Begins 2,640' downstream from CMS; Extends to just past 1st Lane Closure Sign

Area 2: Begins just past the 1st Lane Closure Sign; Extends to just past the last Lane Closure Sign

MEASUREMENT AND PAYMENT

Work Zone Presence Lighting will be measured and paid as the maximum number of lighting units satisfactorily placed, accepted by the Engineer, and in use at any one time during the life of the project.

Relocation, replacement, repair, removal, and maintenance of Work Zone Presence Lighting units will be incidental to the work of this section. No measurement or separate payment will be made for power generators, batteries, or other power supply devices.

Pay Item

Work Zone Presence Lighting

Pay Unit

Each

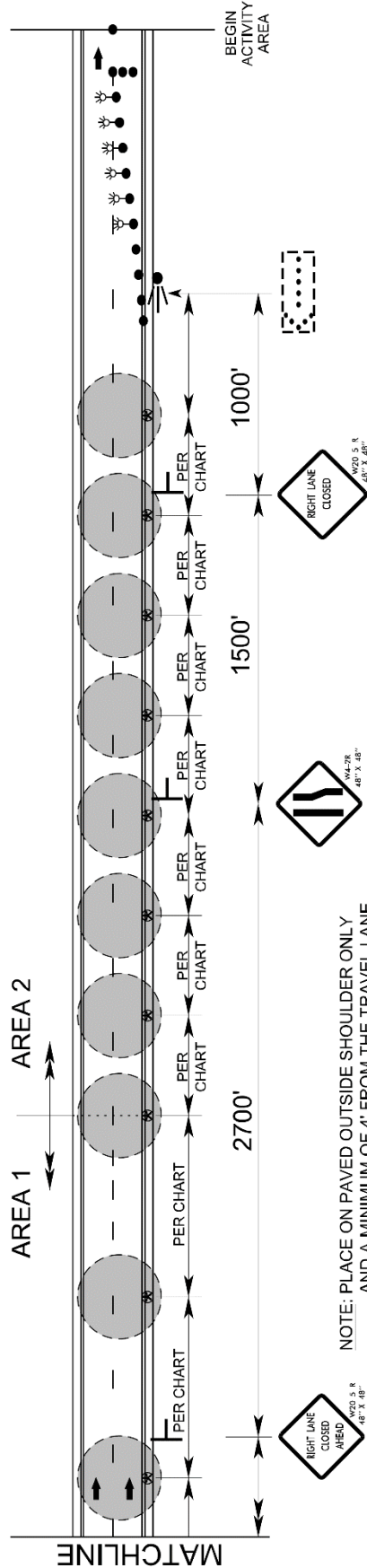
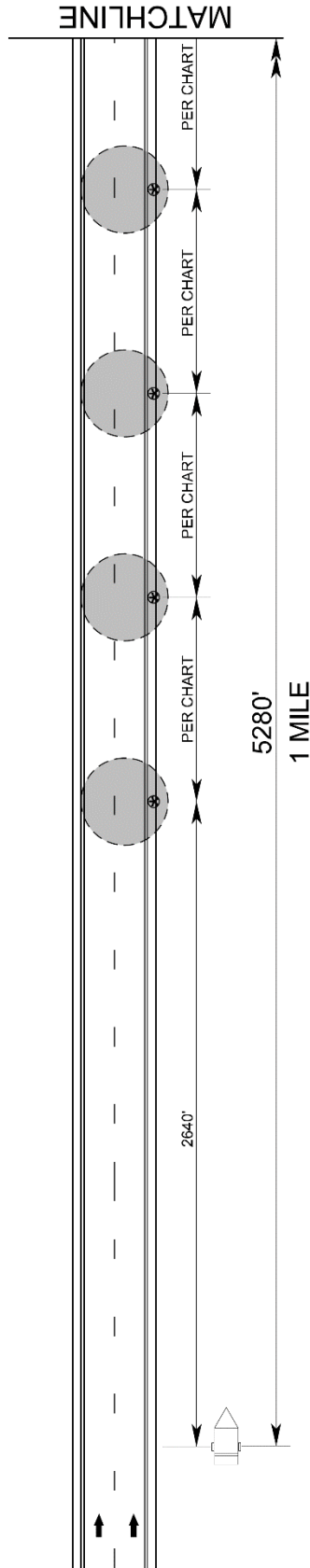

NOTE: PLACE ON PAVED OUTSIDE SHOULDER ONLY AND A MINIMUM OF 4' FROM THE TRAVEL LANE.

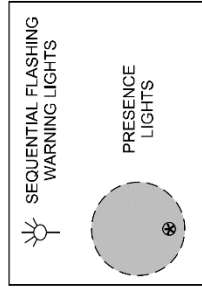

SPACING CHART

Light Output (Lumens)	AREA 1		AREA 2	
	Fixture Area (Minimum)	# of Lights	Spacing*	# of Lights
14K to 35K	4	6	640' (16 skips)	8
35.1K to 60K	5	5	800' (20 skips)	6
60K +	6+	4	1000' (25 skips)	5

*SKIPS REFER TO TRADITIONAL 10' PAVEMENT MARKING LINES WITH 30' GAPS.

AREA 1: BEGINS 2,640' DOWNSTREAM FROM CMS; EXTENDS TO JUST PAST 1ST LANE CLOSURE SIGN

AREA 2: BEGINS JUST PAST THE 1ST LANE CLOSURE SIGN; EXTENDS TO JUST PAST THE LAST LANE CLOSURE SIGN

HIGH VISIBILITY DEVICES

(10/25/2019) (Rev. 5/19/2026)

Description

Furnish and install high visibility devices on all roadways within the project limits with speed limits of 55 mph or higher.

Materials

(A) General

Use the following high visibility devices for work zone performance applications that are listed on the NCDOT APL.

- (a) Drums
- (b) Skinny Drums
- (c) Work Zone Stationary Signs
- (d) Work Zone Rigid Portable Signs (nighttime use)

All drums and skinny drums shall meet the requirements of Article 1089-5 of the *Standard Specifications* and shall have Grade B flexible, fluorescent orange sheeting that meets the retroreflective requirements of Article 1092-2 of the *Standard Specifications*.

All stationary work zone signs shall meet the requirements of Articles 1089-1 and 1089-2 of the *Standard Specifications*. Legend overlays are prohibited. Vertical sign post reflector strips shall be added to all stationary sign supports. Use Grade B fluorescent orange for work zone sign supports and Grade B fluorescent yellow for exit sign supports. Install sign post reflector strips a minimum of 2" wide, a minimum of 6' long on sign supports with one sign mounted and a minimum of 4.5' long for sign supports with two or more signs mounted vertically.

All portable work zone signs shall meet the requirements of Article 1089-1 and 1089-2 of the *Standard Specifications*. However, roll-up signs are prohibited for night work.

(B) Material Qualifications/Certifications

Provide a Type 3 Material Certification for all materials in accordance with Articles 106-3 and 1087-4 of the *Standard Specifications*.

Construction Methods

Install high visibility devices in accordance with this special provision and the applicable requirements of Section 1110, 1130 and 1180 of the *Standard Specifications*.

Maintenance

Replace any sign or drum that prematurely fails due to any damage or defect that causes it to perform unsatisfactorily with a device of similar quality and age according to the guidelines set forth in the American Traffic Safety Service Association’s (ATSSA) Quality Guidelines for Work Zone Traffic Control Devices.

Measurement and Payment

High Visibility Drums will be measured and paid as the maximum number of drums placed and in use at any one time during the life of the project.

High Visibility Skinny Drums will be measured and paid as the maximum number of skinny drums placed and in use at any one time during the life of the project.

High Visibility Stationary Signs will be measured as the actual number of square feet satisfactorily installed at each location and accepted by the Engineer. Where a particular sign is used at more than one location, measurement will be made at each location.

High Visibility Portable Signs will be measured and paid as the actual number of square feet satisfactorily installed and accepted by the Engineer. Payment will be made for the initial installation only. Relocation of signs will be incidental to the measurement of the quantity of High Visibility Portable Signs.

No direct payment will be made for work zone high visibility stationary sign supports or portable sign stands. All work zone high visibility stationary sign supports or portable sign stands will be incidental to the work of providing *High Visibility Stationary Signs* or *High Visibility Portable Signs* respectively. Relocation, replacement, repair, disposal and maintenance of high visibility devices will be incidental to the work of this special provision. Relocation, replacement, repair, disposal or maintenance of ballasts or reflective sheeting will be incidental to the work of this special provision.

Payment will be made under:

Pay Item:	Pay Unit
High Visibility Drums	Each
High Visibility Skinny Drums	Each
High Visibility Stationary Signs	Square Foot
High Visibility Portable Signs	Square Foot

PROJECT SPECIAL PROVISIONS
LIGHTING

1.00 DESCRIPTION

Replace damaged or faulty luminaires and tunnel lighting bracket assemblies and troubleshoot and repair faults within the existing tunnel lighting systems serving the three I-40 tunnels in Haywood County.

Perform all work in conformance with the following: Division 14 of the 2024 *North Carolina Department of Transportation Standard Specifications for Roads and Structures (Standard Specifications)* except as modified or added to by these Special Provisions; the original lighting design plans; and the 2020 *National Electrical Code (NEC)*.

Specific Sections of the *Standard Specifications* applicable to the work on this project are listed below.

Section 1409	Electrical Duct
Section 1410	Feeder Circuits
Section 1411	Electrical Junction Boxes

Install any required bore pits outside the clear zone, as defined in the *AASHTO Roadside Design Guide* or as directed by the Engineer.

2.00 TUNNEL LIGHTING LUMINAIRES**2.10 DESCRIPTION**

The work covered in this section consists of removal of a faulty tunnel lighting luminaire, tightening of the existing bracket attachment mechanism and the installation of a new tunnel lighting luminaire, complete with all light sources and drivers. Tunnel lighting luminaire is installed on a custom fabricated bracket assembly mounted to the interior of the tunnel at approximately 20 ft. in height.

2.20 MATERIALS

To match existing lighting within the tunnels, the tunnel lighting luminaire shall be a Cooper Lighting Streetworks Galleon II with the following part number:

BAA-GLAN-SA4C-740-8-5MQ-AP-20K

Provide blue threadlocker for use on all connecting hardware.

New bracket assemblies are not part of this section.

Provide 2 #12 w/G THHN/THWN conductor from the luminaire to the junction box.

2.30 LUMINAIRE WARRANTY

Provide a minimum ten-year warranty covering maintained integrity and functionality of the luminaire housing, wiring, and connections, LED light source(s) and LED driver. Negligible light output from more than 10 percent of the LED packages, color shifting, or flickering/strobing not related to incoming power issues all constitute luminaire failure.

Warranty period shall begin after project acceptance by the Department. Contractor shall furnish documentation of warranty procedures stating that warranty is for the Department.

2.40 CONSTRUCTION METHODS

Coordinate work with the NCDOT Division 14 Bridge Maintenance Engineer to assure that circuits can be de-energized where and when necessary.

Remove existing faulty luminaire from custom bracket assembly mounted to the interior tunnel walls. Also remove the bracket assembly by removing bracket securing nuts, leveling nuts and washers from threaded rod. Set bracket assembly, bracket securing nuts, leveling nuts and washers to the side. Loosen anchor securing nuts one at a time, apply blue threadlocker to bolt threads and retighten anchor securing nut. Torque anchor securing nut to 40-44 ft-lb. Reinstall leveling nuts, washers, bracket assembly and bracket securing nuts. Use blue threadlocker on each nut to prevent loosening from vibrations. Torque each bracket securing nut to 150 ft-lb.

Remove all existing #12 conductor in the liquid tight flexible metal conduit between the bracket assembly and the 4"x4"x4" junction box and replace with new.

Install new luminaire on the existing bracket assembly using blue threadlocker for each screw or bolt connection. Level and secure each luminaire in all directions. Adjust any luminaires, as directed by the Engineer, to provide optimal illumination distribution.

Dispose of removed luminaire and conductor in a manner acceptable to the Engineer.

All LED packages on the new luminaire must be burning at full brightness with no flickering, strobing or signs of color shifting apparent, at contract completion. If the luminaire or any LED package on the new luminaire displays improper operating characteristics prior to contract completion, the Contractor shall replace the luminaire with another new luminaire at no additional cost to the Department.

2.50 MEASUREMENT AND PAYMENT

The *Tunnel Lighting Luminaire*, measured as provided above, will be paid for at the contract unit price per each Tunnel Lighting Luminaire accepted by the Engineer. Such price and payment will be considered full compensation for removing the faulty luminaire, applying threadlocker to all existing hardware connection points, and providing and installing the new tunnel lighting

luminaire on an existing bracket arm. The removal and replacement of the #12 conductor shall be paid for under Section 5.00 of these Special Provisions.

Payment will be made under:

Pay Item	Pay Unit
Tunnel Lighting Luminaire	Each

3.00 LIGHT STANDARD LIGHT EMITTING DIODE (LED) LUMINAIRE

3.10 DESCRIPTION

The work covered in this section consists of removal of an existing light standard luminaire and the installation of a new light standard luminaire on a bracket arm assembly, complete with all light sources, drivers, wiring inside standard from circuit conductors to luminaire, in-line breakaway fuseholders and fuses and ground wiring at the pole on light standards less than 55 ft. in height.

Any light standard luminaire submitted for approval must meet the minimum requirements in the table and sections below.

Type	HPS Replacement Equivalent	Color Temp	Min. % of initial output at 70k hours	Min. Maintained Delivered Lumens
185W LED	250W	3500K ±500K	83%	15,500

Third party certified photometric files in IES format are required to be submitted with the catalog cuts for the proposed LED roadway luminaire. Photometric files must show that the proposed luminaire will meet or exceed the design shown in the plans.

The manufacturer shall state the Light Loss Factor (LLF) used in the photometric calculations for the proposed luminaire. LLF shall be calculated as follows:

$$LLF = \text{Lamp Lumen Depreciation (LLD)} \times \text{Luminaire Dirt Depreciation (LDD)}$$

- A. Lamp Lumen Depreciation (LLD) shall be the value calculated and reported by the manufacturer based on the LM-80 and TM-21 reports for the proposed fixture for 70,000 hours at 25° C.
- B. Luminaire Dirt Depreciation (LDD) = 0.90

3.20 MATERIALS

3.21 LUMINAIRE REQUIREMENTS

A. General Requirements

- (1) LM-79 photometric test reports shall be provided for all LED luminaires. LM-79 luminaire photometric reports shall be produced by an independent test laboratory and include the following:

- (a) Name of test laboratory. The test laboratory must hold National Voluntary Laboratory Accreditation Program (NVLAP) accreditation for the IES LM-79 test procedure or must be qualified, verified, and recognized through the U.S. Department of Energy's CALiPER program.
 - (b) Report number
 - (c) Date
 - (d) Complete luminaire catalog number. Catalog number tested must match the catalog number of the luminaire submitted, except for variations which do not affect performance.
 - (e) Description of luminaire, LED light source(s), and LED driver(s)
 - (f) Goniophotometry
 - (g) Colorimetry
- (2) LM-80 lumen maintenance test report shall be provided for each respective LED light source.
 - (3) Luminaire shall be constructed of a single piece die cast aluminum housing. Each luminaire shall be finished gray in color unless otherwise noted.
 - (4) The luminaire shall have a 7 pin ANSI C136.41 compliant photocontrol receptacle for future expansion capabilities.
 - (5) Provide a summary of reliability testing performed for LED driver.
 - (6) Luminaires maximum total power consumption shall not exceed the values shown in the table above. Nominal luminaire input wattage shall account for nominal applied voltage and any reduction in driver efficiency due to sub-optimal driver loading.
 - (7) Luminaire shall have a maximum Backlight, Uplight & Glare (BUG) rating of 3-0-3 and an IESNA distribution of Type II or Type III as required to meet the spacing, the average maintained footcandle level and the average to minimum uniformity ratio requirements shown on the plans. The same BUG rating and distribution type shall be used throughout the project.
 - (8) Minimum Ingress Protection (IP) dust and moisture ratings for the luminaire electrical components (driver and surge protection) and luminaire optical components shall be IP65 and IP66, respectively, as specified in ANSI C136.25.
 - (9) Luminaire shall have external and internal labels per ANSI C136.15 and ANSI C136.22, respectively. Internal label shall identify the manufacturer, year and month of manufacture and the manufacturer's part number.
 - (10) Luminaire shall have an internal bubble level.
 - (11) Luminaires shall start and operate in -20°C to +40°C ambient.
 - (12) Luminaires shall be rated for continuous service at an ambient temperature of 40°C (104°F)
 - (13) Electrically test fully assembled luminaires before shipment from factory.
 - (14) Effective Projected Area (EPA) and weight of the luminaires shall not exceed 1.4 square feet and 46 lbs.
 - (15) Luminaires shall be designed for ease of electrical component replacement.
 - (16) Luminaires shall be rated for minimum 2G vibration, minimum, per ANSI C136.31.
 - (17) LED light sources and drivers shall be RoHS compliant.

- (18) The luminaire manufacturer shall have no less than five (5) years of experience in manufacturing LED-based lighting products and the manufacturing facility must be ISO 9001 certified.
- (19) Luminaire shall have a 1.25" to 2.0" adjustable tenon mount for connection to luminaire bracket arm assembly.
- (20) Pole hardware, nuts, bolts, and washers, etc. shall be made from 18-8 stainless steel, or steel conforming to ASTM A307 galvanized in accordance with ASTM A153.
- (21) Grommets shall be installed in cable entry holes. Cable entry holes shall be free from sharp edges which might cut conductors or an ungloved hand.
- (22) All conductors inside the luminaire shall be neatly secured with tie-wraps as needed to prevent pinch points and assist in trouble shooting.

B. Driver

- (1) Shall be 0V-10V dimmable.
- (2) Rated case temperature shall be suitable for operation in the luminaire operating in the ambient temperature range of -20°C to +40°C.
- (3) Shall be rated for 480VAC at 50/60 Hz, and shall operate normally for input voltage fluctuations of $\pm 10\%$.
- (4) Shall have a minimum Power Factor (PF) of 0.90 at full input power and across specified voltage range.
- (5) Shall provide UL Class II output.

C. Surge Suppression

- (1) Integral surge protection shall meet ANSI/IEEE C62.45 procedures based on ANSI/IEEE C62.41.2 definitions for standard and optional waveforms for location category C-High 10kV/10kA test, IEC 61000-4-2 (Electrostatic Discharge) 8kV Air/4kV Contact test and IEC 61000-4-4 (Fast Transients).

D. Electromagnetic Interference

- (1) Luminaires shall have a maximum Total Harmonic Distortion (THD) of 20% at full input power and across specified voltage range.
- (2) Luminaires shall comply with FCC 47 CFR part 15 non-consumer RFI/EMI standards.

E. Electrical Safety Testing

- (1) Luminaires shall be listed for wet locations.
- (2) Luminaires shall be UL listed and labeled.

F. Finish

- (1) Luminaires shall be painted with a corrosion resistant polyester powdered paint with a minimum 2.0 mil thickness.
- (2) Luminaires shall exceed a rating of six per ASTM D1654 after 1000 hours of salt spray fog testing per ASTM B117.
- (3) The coating shall exhibit no greater than 30% reduction of gloss per ASTM D523, after 500 hours of QUV testing at ASTM G154 Cycle 6.
- (4) Exterior surfaces shall be smooth and free of burrs.

G. Thermal Management

- (1) Mechanical design of protruding external surfaces (heat sink fins) on roadway luminaires shall facilitate hose-down cleaning and discourage debris accumulation.
- (2) Liquids or moving parts will not be allowed for thermal management.

H. Color Quality

- (1) Minimum Color Rendering Index (CRI) of 70 with a Correlated Color Temperature (CCT) of 3000K to 4000K.

I. Optics

- (1) Transmissive optical components shall be applied in accordance with OEM design guidelines to ensure suitability for the thermal/mechanical/chemical environment.

J. ANSI C136.37 Compliance

- (1) All internal components shall be assembled and pre-wired using modular electrical connections.
- (2) Terminal blocks shall be used for incoming AC lines. Terminal blocks shall be easily accessible to installers or repair personnel. Wire nuts are prohibited inside the luminaire housing.

K. Latching and Hinging

- (1) Refractor and housing door holders and hinges shall be designed to maintain positive control of door to the luminaire body so as not to allow the accidental disengagement of either door.
- (2) Drivers shall be mounted to a housing door designed to be opened from the bottom of the luminaire. Housing door shall allow easy removal for troubleshooting/repair on the ground.

L. Manufacturer Support

- (1) Manufacturer or local sales representative shall provide installation and troubleshooting support via telephone and/or email.

Include a shorting cap for each luminaire provided.

Remove existing wiring and breakaway fuseholders inside the light standard. Provide new wiring inside the light standard, new breakaway fuseholders and new fuses meeting Article 1400-2 of the *Standard Specifications*, respectively.

3.30 WARRANTY

Provide a minimum ten-year warranty covering maintained integrity and functionality of the luminaire housing, wiring, and connections, LED light source(s) and LED driver. Negligible light output from more than 10 percent of the LED packages, color shifting, or flickering/strobing not related to incoming power issues all constitute luminaire failure.

Warranty period shall begin after project acceptance by the Department. Supplier shall furnish documentation of warranty procedures to the Contractor stating that warranty is for the Department.

3.40 CONSTRUCTION METHODS

Coordinate work with the NCDOT Division 14 Bridge Maintenance Engineer to assure that circuits can be de-energized where and when necessary.

Remove luminaire from pole arm bracket assembly. Remove all existing wiring and fuseholders within the standard. Dispose of the removed luminaire, wiring and breakaway fuseholders in a manner acceptable to the Engineer.

Install new wiring inside the standard from circuit conductors to luminaire, new in-line breakaway fuseholders and fuses and new ground wiring at the standard.

Install new luminaire on existing bracket arm. Level and secure luminaire in all directions. Adjust any luminaires, as directed by the Engineer, to provide optimal illumination distribution.

All LED packages on all luminaires must be operating normally at contract completion. Any luminaire displaying improper operating characteristics prior to contract completion will be replaced by the Contractor at no additional cost to the Department.

3.50 MEASUREMENT AND PAYMENT

The *Light Standard Luminaire*, measured as provided above, will be paid for at the contract unit price per each Light Standard Luminaires, Type RDW 185W LED accepted by the Engineer. Such price and payment will be considered full compensation for removing and disposing of existing luminaire and wiring within the standard, and providing and installing the new LED light standard luminaire on the bracket arm, wiring inside the standard from the circuit conductors to the LED light standard luminaire, in-line breakaway fuseholders with fuses, ground wiring at the pole of the light standard and a shorting cap.

Payment will be made under:

Pay Item	Pay Unit
Light Standard Luminaires, Type RDW 185W LED	Each

4.00 TUNNEL LUMINAIRE BRACKET ASSEMBLY

4.10 DESCRIPTION

The work covered by this section consists of removing and replacing any failing or damaged luminaire bracket assemblies within the existing lighting systems serving the three I-40 tunnels in Haywood County.

4.20 MATERIALS

Luminaire supports are custom brackets, fabricated from ¼” plate steel and 4” square straight steel pole sections that have a wall thickness of 0.188”. Bracket components are welded together and hot dip galvanized after fabrication. Each bracket will have a ground lug near the removable endcap. Endcap and bracket shall utilize a concealed safety wire strap that prevents the endcap from falling when it is removed from the bracket.

4.30 CONSTRUCTION METHODS

Remove existing luminaire from custom bracket assembly mounted to the interior tunnel walls. Unless the luminaire is faulty or otherwise damaged, the luminaire shall be reused. Remove the damaged or faulty bracket assembly by removing bracket securing nuts, leveling nuts and washers from threaded rod. Set bracket securing nuts, leveling nuts and washers to the side. Loosen anchor securing nuts one at a time, apply blue threadlocker to bolt threads and retighten anchor securing nut. Torque anchor securing nut to 40-44 ft-lb. Reinstall leveling nuts, washers, new bracket assembly and bracket securing nuts. Use blue threadlocker on each nut to prevent loosening from vibrations. Torque each bracket securing nut to 150 ft-lb.

Reinstall removed luminaire on the new bracket assembly using blue threadlocker for each screw or bolt connection. Level and secure each luminaire in all directions. Adjust any luminaires, as directed by the Engineer, to provide optimal illumination distribution.

Dispose of removed bracket assembly in a manner acceptable to the Engineer.

4.40 MEASUREMENT & PAYMENT

The *Tunnel Lighting Bracket Assembly*, measured as provided above, will be paid for at the contract unit price per each Tunnel Lighting Bracket Assembly accepted by the Engineer. Such price and payment will be considered full compensation for removing and disposing of the old bracket assembly, applying threadlocker to all existing hardware connection points, providing and installing the new tunnel lighting bracket assembly and reinstalling the luminaire.

Payment will be made under:

Pay Item	Pay Unit
Tunnel Lighting Bracket Assembly	Each

5.00 TROUBLESHOOT & REPAIR EXISTING LIGHTING SYSTEM**5.10 DESCRIPTION**

The work covered by this section consists of finding and repairing faults with the existing lighting systems serving the three I-40 tunnels in Haywood County.

5.20 MATERIALS

Use a Meg Tester, Digital Multi-Meter, and other applicable test equipment and tools for *Fault Troubleshoot and Locate*.

Provide THHN/THWN conductor of the appropriate color for any conductor replaced above finished grade or in the stainless-steel controller enclosures. Refer to the original design plans for correct color coding of conductor. All new wiring shall have colored insulation along its entire length. No circuit may change color at any point except where transitioning to type USE wire at in ground junction boxes.

Refer to Division 14 of the *Standard Specifications* for the following items:

Item	Section
2 #6 w/G Feeder Circuit	1410-2
2 #6 w/G Feeder Circuit in 1.5" Conduit	1410-2
2 #8 w/G Feeder Circuit	1410-2
2 #8 w/G Feeder Circuit in 1.5" Conduit	1410-2
Electrical Junction Boxes (Size & Type)	1411-2
Electrical Duct	1409-2

5.30 CONSTRUCTION METHODS

Troubleshoot and replace faulty electrical circuitry or equipment with new materials to make the existing lighting system fully operational.

Original lighting design plans will be provided to the Contractor to aid in troubleshooting.

Troubleshoot and replace faulty feeder circuit run in conduit on the exterior or interior tunnel wall or within the stainless-steel enclosures. Replacement conductors must be of the same size and color as the faulty conductor. In the case of a faulty circuit run shoulder areas, the Contractor may either replace the conductors inside the existing conduit; or abandon or remove the existing conductors and conduit of the faulty circuit run in accordance with Section 1400-10, and reinstall new conduit and new conductors for the run. Label all new conductors as shown in the plans provided as part of the contract.

All splicing shall be done in accordance with Section 1400-4(F) of the *Standard Specifications*.

Coordinate work with the NCDOT Division 14 Bridge Maintenance Engineer to assure that circuits can be de-energized where and when necessary.

Upon project completion, the lighting system shall be fully operational. All the lights shall be burning at full brightness, with all circuits passing inspections and performance tests.

If existing material is to be reused, the Contractor shall be responsible for the storage and protection of the reused materials against loss or damage.

All removed faulty materials shall be disposed of in a manner acceptable to the Engineer.

5.40 MEASUREMENT AND PAYMENT

Troubleshoot and Repair Existing Lighting System will be measured and paid for at the contract unit bid price of each applicable pay item listed below. Such price and payment will be considered full compensation for troubleshooting, disconnecting circuitry, disassembly, connecting of new circuitry, testing, and all equipment and incidentals necessary to make the existing lighting systems fully operational.

Estimated quantities shown in the "Itemized Proposal" are for obtaining bid prices only. Actual quantities will be paid for as measured below.

Fault Troubleshoot and Locate will be measured and paid for at the contract unit price for the actual number of hours spent in troubleshooting the existing lighting system, to determine the cause of non-functioning equipment that has been accepted by the Engineer.

2 #6 w/G Feeder Circuit will be measured and paid for in accordance with Section 1410-4.

2 #6 w/G Feeder Circuit in 1-1/2" Conduit will be measured and paid for in accordance with Section 1410-4.

2 #8 w/G Feeder Circuit will be measured and paid for in accordance with Section 1410-4.

2 #8 w G Feeder Circuit in 1-1/2" Conduit will be measured and paid for in accordance with Section 1410-4.

1 #6 THHN/THWN Conductor will be measured and paid for at the contract unit price for the actual number of linear feet completed and accepted by the Engineer. Measurement will be rounded up to the nearest whole foot of #6 THHN/THWN conductor of the appropriate color installed within existing conduit on the exterior or interior tunnel walls or within the stainless-steel enclosures. Such price and payment will be considered full compensation for providing and installing the new #6 conductor, labeling of the conductor, as well as removal and disposal of the faulty #6 conductor.

1 #8 THHN/THWN Conductor will be measured and paid for at the contract unit price for the actual number of linear feet completed and accepted by the Engineer. Measurement will be rounded up to the nearest whole foot of #8 THHN/THWN conductor of the appropriate color installed within existing conduit on the exterior or interior tunnel walls or within the stainless-steel enclosures. Such price and payment will be considered full compensation for providing and installing the new #8 conductor, labeling of the conductor, as well as removal and disposal of the faulty #8 conductor.

1 #12 THHN/THWN Conductor will be measured and paid for at the contract unit price for the actual number of linear feet completed and accepted by the Engineer. Measurement will be rounded up to the nearest whole foot of #12 THHN/THWN conductor of the appropriate color installed within existing LFMC between the luminaire and the 4"x4"x4" wall mounted junction

box. Such price and payment will be considered full compensation for providing and installing the new #12 conductor, labeling of the conductor, as well as removal and disposal of the faulty #12 conductor.

Electrical Junction Boxes, (Size & Type) will be measured and paid for in accordance with Section 1411-4.

Electrical Duct, (Size & Type) will be measured and paid for in accordance with Section 1409-4.

Payment will be made under:

Pay Item	Pay Unit
Fault Troubleshoot and Locate	HR
2 #6 w/G Feeder Circuit	LF
2 #6 w/G Feeder Circuit in 1-1/2" Conduit	LF
2 #8 w/G Feeder Circuit	LF
2 #8 w/G Feeder Circuit in 1-1/2" Conduit	LF
1 #6 THHN/THWN Conductor	LF
1 #8 THHN/THWN Conductor	LF
1 #12 THHN/THWN Conductor	LF
Electrical Junction Boxes, (Size & Type)	EA
Electrical Duct, (Size & Type)	LF



DocuSigned by:

Sarah Kirkpatrick 04/28/2026

7ACCC8DB119E46C...

DOCUMENT NOT CONSIDERED FINAL
UNLESS ALL SIGNATURES COM

PROJECT SPECIAL PROVISIONS**EROSION CONTROL****CONSTRUCTION MATERIALS MANAGEMENT**

(3-19-19) (rev. 04-27-20)

Description

The requirements set forth shall be adhered to in order to meet the applicable materials handling requirements of the NCG010000 permit. Structural controls installed to manage construction materials stored or used on site shall be shown on the E&SC Plan. Requirements for handling materials on construction sites shall be as follows:

Polyacrylamides (PAMS) and Flocculants

Polyacrylamides (PAMS) and flocculants shall be stored in leak-proof containers that are kept under storm-resistant cover or surrounded by secondary containment structures designed to protect adjacent surface waters. PAMS or other flocculants used shall be selected from the NC DWR List of Approved PAMS/Flocculants. The concentration of PAMS and other flocculants used shall not exceed those specified in the NC DWR List of Approved PAMS/Flocculants and in accordance with the manufacturer's instructions. The NC DWR List of Approved PAMS/Flocculants is available at:

https://files.nc.gov/ncdeq/Water+Quality/Environmental+Sciences/ATU/PAM8_30_18.pdf

Equipment Fluids

Fuels, lubricants, coolants, and hydraulic fluids, and other petroleum products shall be handled and disposed of in a manner so as not to enter surface or ground waters and in accordance with applicable state and federal regulations. Equipment used on the site must be operated and maintained properly to prevent discharge of fluids. Equipment, vehicle, and other wash waters shall not be discharged into E&SC basins or other E&SC devices. Alternative controls should be provided such that there is no discharge of soaps, solvents, or detergents.

Waste Materials

Construction materials and land clearing waste shall be disposed of in accordance with North Carolina General Statutes, Chapter 130A, Article 9 - Solid Waste Management, and rules governing the disposal of solid waste (15A NCAC 13B). Areas dedicated for managing construction material and land clearing waste shall be at least 50 feet away from storm drain inlets and surface waters unless it can be shown that no other alternatives are reasonably available. Paint and other liquid construction material waste shall not be dumped into storm drains. Paint and other liquid construction waste washouts should be located at least 50 away from storm drain inlets unless there is no alternative. Other options are to install lined washouts or use portable, removable bags or bins. Hazardous or toxic waste shall be managed in accordance with the federal Resource

Conservation and Recovery Act (RCRA) and NC Hazardous Waste Rules at 15A NCAC, Subchapter 13A. Litter and sanitary waste shall be managed in a manner to prevent it from entering jurisdictional waters and shall be disposed of offsite.

Herbicide, Pesticide, and Rodenticides

Herbicide, pesticide, and rodenticides shall be stored and applied in accordance with the Federal Insecticide, Fungicide, and Rodenticide Act, North Carolina Pesticide Law of 1971 and labeling restrictions.

Concrete Materials

Concrete materials onsite, including excess concrete, must be controlled and managed to avoid contact with surface waters, wetlands or buffers. No concrete or cement slurry shall be discharged from the site. (Note that discharges from onsite concrete plants require coverage under a separate NPDES permit – NCG140000.) Concrete wash water shall be managed in accordance with the *Concrete Washout Structure* provision. Concrete slurry shall be managed and disposed of in accordance with *NCDOT DGS and HOS DCAR Distribution of Class A Residuals Statewide* (Permit No. WQ0035749). Any hardened concrete residue will be disposed of, or recycled on site, in accordance with state solid waste regulations.

Earthen Material Stock Piles

Earthen material stock piles shall be located at least 50 feet away from storm drain inlets and surface waters unless it can be shown that no other alternatives are reasonably available.

Measurement and Payment

Conditions set within the *Construction Materials Management* provision are incidental to the project for which no direct compensation will be made.

WASTE AND BORROW SOURCES:

(2-16-11) (Rev. 3-17-22)

Payment for temporary erosion control measures, except those made necessary by the Contractor's own negligence or for his own convenience, will be paid for at the appropriate contract unit price for the devices or measures utilized in borrow sources and waste areas.

No additional payment will be made for erosion control devices or permanent seeding and mulching in any commercial borrow or waste pit. All erosion and sediment control practices that may be required on a commercial borrow or waste site will be done at the Contractor's expense.

All offsite Staging Areas, Borrow and Waste sites shall be in accordance with "Borrow and Waste Site Reclamation Procedures for Contracted Projects" located at:

<https://connect.ncdot.gov/resources/roadside/FieldOperationsDocuments/Contract%20Reclamation%20Procedures.pdf>

All forms and documents referenced in the "Borrow and Waste Site Reclamation Procedures for Contracted Projects" shall be included with the reclamation plans for offsite staging areas, and borrow and waste sites.

LISTING OF MBE/WBE SUBCONTRACTORS

Sheet of

Firm Name and Address	Circle One	Item No.	Item Description	* Agreed upon Unit Price	** Dollar Volume of Item
Name Address	MBE WBE				
Name Address	MBE WBE				
Name Address	MBE WBE				
Name Address	MBE WBE				
Name Address	MBE WBE				
Name Address	MBE WBE				

* The Dollar Volume shown in this column shall be the Actual Price Agreed Upon by the Prime Contractor and the MBE/WBE subcontractor, and these prices will be used to determine the percentage of the MBE/WBE participation in the contract.

** Dollar Volume of MBE/WBE Subcontractor Percentage of Total Contract Bid Price:

If firm is a Material Supplier Only, show Dollar Volume as 60% of Agreed Upon Amount from Letter of Intent.

If firm is a Manufacturer, show Dollar Volume as 100% of Agreed Upon Amount from Letter of Intent.

LISTING OF MBE/WBE SUBCONTRACTORS

Sheet of

Firm Name and Address	Circle One	Item No.	Item Description	* Agreed upon Unit Price	** Dollar Volume of Item
Name Address	MBE WBE				
Name Address	MBE WBE				
Name Address	MBE WBE				
Name Address	MBE WBE				
Name Address	MBE WBE				

**** Dollar Volume of MBE Subcontractor** \$ _____

MBE Percentage of Total Contract Bid Price _____%

**** Dollar Volume of WBE Subcontractor** \$ _____

WBE Percentage of Total Contract Bid Price _____%

***The Dollar Volume shown in this column shall be the Actual Price Agreed Upon by the Prime Contractor and the MBE/WBE subcontractor, and these prices will be used to determine the percentage of the MBE/WBE participation in the contract.**

**** Dollar Volume of MBE/WBE Subcontractor Percentage of Total Contract Bid Price.**

If firm is a Material Supplier Only, show Dollar Volume as 60% of Agreed Upon Amount from Letter of Intent.

If firm is a Manufacturer, show Dollar Volume as 100% of Agreed Upon Amount from Letter of Intent.

ADDENDA

ADDENDUM #1

I, _____ representing _____
(SIGNATURE)

Acknowledge receipt of Addendum #1.

ADDENDUM #2

I, _____ representing _____
(SIGNATURE)

Acknowledge receipt of Addendum #2.

ADDENDUM #3

I, _____ representing _____
(SIGNATURE)

Acknowledge receipt of Addendum #3.

AWARD LIMITS ON MULTIPLE PROJECTS

It is the desire of the Proposer to be awarded contracts, the value of which will not exceed a total of \$ _____, for those projects indicated below on which bids are being opened on the same date as shown in the Proposal Form. Individual projects shall be indicated by placing the project number and county in the appropriate place below. Projects not selected will not be subject to an award limit.

(Project Number)

(County)

(Project Number)

(County)

(Project Number)

(County)

(Project Number)

(County)

*If a Proposer desires to limit the total amount of work awarded to him in this letting, he shall state such limit in the space provided above in the second line of this form.

It is agreed that in the event that I am (we are) the successful bidder on indicated projects, the total value of which is more that the above stipulated award limits, the Board of Transportation will award me (us) projects from among those indicated which have a total value not exceeding the award limit and which will result in the best advantage to the Department of Transportation.

**Signature of Authorized Person

**Only those persons authorized to sign bids under Subarticle 102-8(A)(12) shall be authorized to sign this form.

NON-COLLUSION, DEBARMENT AND GIFT BAN CERTIFICATION

CORPORATION

The prequalified bidder, declares (or certifies, verifies, or states) under penalty of perjury under the laws of the United States that neither he, nor any official, agent or employee has entered into any agreement, participated in any collusion, or otherwise taken any action which is in restraint of free competitive bidding in connection with any bid or contract, that the prequalified bidder has not been convicted of violating *N.C.G.S. §133-24* within the last three years, and that the prequalified bidder intends to do the work with his own bona fide employees or subcontractors and will not bid for the benefit of another contractor.

By submitting this non-collusion, debarment and gift ban certification, the prequalified bidder is attesting his status under penalty of perjury under the laws of the United States in accordance with the Debarment Certification attached, provided that the Debarment Certification also includes any required statements concerning exceptions that are applicable.

N.C.G.S. §133-32 and Executive Order 24 prohibit the offer to, or acceptance by, any State Employee of any gift from anyone with a contract with the State, or from any person seeking to do business with the State. By execution of any response in this procurement, you attest, for your entire organization and its employees or agents, that you are not aware that any such gift has been offered, accepted, or promised by any employees of your organization.

SIGNATURE OF PREQUALIFIED BIDDER

Full name of Corporation

Address as prequalified

Attest _____
Signature of **Secretary, Assistant Secretary**
Select appropriate title

By _____
Signature of **President, Vice President, Assistant Vice President**
Select appropriate title

Print or type Signer's name

Print or type Signer's name

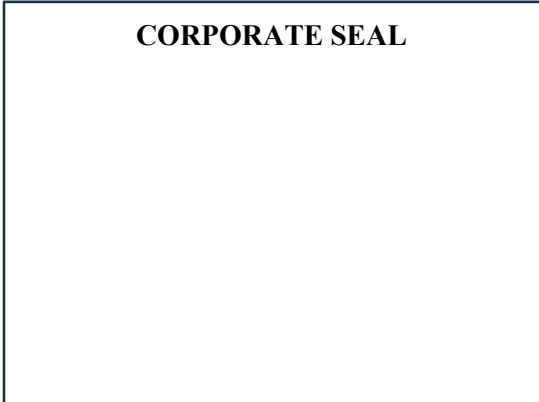

NON-COLLUSION, DEBARMENT AND GIFT BAN CERTIFICATION

PARTNERSHIP

The prequalified bidder, declares (or certifies, verifies, or states) under penalty of perjury under the laws of the United States that neither he, nor any official, agent or employee has entered into any agreement, participated in any collusion, or otherwise taken any action which is in restraint of free competitive bidding in connection with any bid or contract, that the prequalified bidder has not been convicted of violating *N.C.G.S. § 133-24* within the last three years, and that the prequalified bidder intends to do the work with its own bona fide employees or subcontractors and will not bid for the benefit of another contractor.

By submitting this non-collusion, debarment and gift ban certification, the prequalified bidder is attesting his status under penalty of perjury under the laws of the United States in accordance with the Debarment Certification attached, provided that the Debarment Certification also includes any required statements concerning exceptions that are applicable.

N.C.G.S. § 133-32 and Executive Order 24 prohibit the offer to, or acceptance by, any State Employee of any gift from anyone with a contract with the State, or from any person seeking to do business with the State. By execution of any response in this procurement, you attest, for your entire organization and its employees or agents, that you are not aware that any such gift has been offered, accepted, or promised by any employees of your organization.

SIGNATURE OF PREQUALIFIED BIDDER

Full name of
Partnership

Address as
prequalified

Signature of Witness

Signature of Partner

Print or type Signer's name

Print or type Signer's name

NON-COLLUSION, DEBARMENT AND GIFT BAN CERTIFICATION

LIMITED LIABILITY COMPANY

The prequalified bidder, declares (or certifies, verifies, or states) under penalty of perjury under the laws of the United States that neither he, nor any official, agent or employee has entered into any agreement, participated in any collusion, or otherwise taken any action which is in restraint of free competitive bidding in connection with any bid or contract, that the prequalified bidder has not been convicted of violating *N.C.G.S. § 133-24* within the last three years, and that the prequalified bidder intends to do the work with its own bona fide employees or subcontractors and will not bid for the benefit of another contractor.

By submitting this non-collusion, debarment and gift ban certification, the prequalified bidder is attesting his status under penalty of perjury under the laws of the United States in accordance with the Debarment Certification attached, provided that the Debarment Certification also includes any required statements concerning exceptions that are applicable.

N.C.G.S. § 133-32 and Executive Order 24 prohibit the offer to, or acceptance by, any State Employee of any gift from anyone with a contract with the State, or from any person seeking to do business with the State. By execution of any response in this procurement, you attest, for your entire organization and its employees or agents, that you are not aware that any such gift has been offered, accepted, or promised by any employees of your organization.

SIGNATURE OF PREQUALIFIED BIDDER

Full name of Firm

Address as prequalified

Signature of Witness

Signature of **Member, Manager, Authorized Agent**
Select appropriate title

Print or type Signer's Name

Print or type Signer's Name

NON-COLLUSION, DEBARMENT AND GIFT BAN CERTIFICATION

JOINT VENTURE (2) or (3)

The prequalified bidder, declares (or certifies, verifies, or states) under penalty of perjury under the laws of the United States that neither he, nor any official, agent or employee has entered into any agreement, participated in any collusion, or otherwise taken any action which is in restraint of free competitive bidding in connection with any bid or contract, that the prequalified bidder has not been convicted of violating N.C.G.S. § 133-24 within the last three years, and that the prequalified bidder intends to do the work with its own bona fide employees or subcontractors and will not bid for the benefit of another contractor.

By submitting this non-collusion, debarment and gift ban certification, the prequalified bidder is attesting his status under penalty of perjury under the laws of the United States in accordance with the Debarment Certification attached, provided that the Debarment Certification also includes any required statements concerning exceptions that are applicable.

N.C.G.S. § 133-32 and Executive Order 24 prohibit the offer to, or acceptance by, any State Employee of any gift from anyone with a contract with the State, or from any person seeking to do business with the State. By execution of any response in this procurement, you attest, for your entire organization and its employees or agents, that you are not aware that any such gift has been offered, accepted, or promised by any employees of your organization.

SIGNATURE OF PREQUALIFIED BIDDER

Instructions: 2 Joint Venturers Fill in lines (1), (2) and (3) and execute. 3 Joint Venturers Fill in lines (1), (2), (3) and (4) and execute. On Line (1), fill in the name of the Joint Venture Company. On Line (2), fill in the name of one of the joint venturers and execute below in the appropriate manner. On Line (3), print or type the name of the other joint venturer and execute below in the appropriate manner. On Line (4), fill in the name of the third joint venturer, if applicable and execute below in the appropriate manner.

(1) _____
Name of Joint Venture
(2) _____
Name of Contractor

Address as prequalified

Signature of Witness or Attest By Signature of Contractor
Print or type Signer's Name and Print or type Signer's Name
If Corporation, affix Corporate Seal

(3) _____
Name of Contractor

Address as prequalified

Signature of Witness or Attest By Signature of Contractor
Print or type Signer's Name and Print or type Signer's Name
If Corporation, affix Corporate Seal

(4) _____
Name of Contractor

Address as prequalified

Signature of Witness or Attest By Signature of Contractor
Print or type Signer's Name and Print or type Signer's Name
If Corporation, affix Corporate Seal

CORPORATE SEAL(S)

NON-COLLUSION, DEBARMENT AND GIFT BAN CERTIFICATION

INDIVIDUAL DOING BUSINESS UNDER A FIRM NAME

The prequalified bidder, declares (or certifies, verifies, or states) under penalty of perjury under the laws of the United States that neither he, nor any official, agent or employee has entered into any agreement, participated in any collusion, or otherwise taken any action which is in restraint of free competitive bidding in connection with any bid or contract, that the prequalified bidder has not been convicted of violating *N.C.G.S. § 133-24* within the last three years, and that the prequalified bidder intends to do the work with its own bona fide employees or subcontractors and will not bid for the benefit of another contractor.

By submitting this non-collusion, debarment and gift ban certification, the prequalified bidder is attesting his status under penalty of perjury under the laws of the United States in accordance with the Debarment Certification attached, provided that the Debarment Certification also includes any required statements concerning exceptions that are applicable.

N.C.G.S. § 133-32 and Executive Order 24 prohibit the offer to, or acceptance by, any State Employee of any gift from anyone with a contract with the State, or from any person seeking to do business with the State. By execution of any response in this procurement, you attest, for your entire organization and its employees or agents, that you are not aware that any such gift has been offered, accepted, or promised by any employees of your organization.

SIGNATURE OF PREQUALIFIED BIDDER

Name of Prequalified Bidder

Print or type Individual Name

Trading and doing business as

Full name of Firm

Address as prequalified

Signature of Witness

Signature of Prequalified Bidder, Individual

Print or type Signer's Name

Print or type Signer's Name

NON-COLLUSION, DEBARMENT GIFT BAN CERTIFICATION

INDIVIDUAL DOING BUSINESS IN HIS OWN NAME

The prequalified bidder, declares (or certifies, verifies, or states) under penalty of perjury under the laws of the United States that neither he, nor any official, agent or employee has entered into any agreement, participated in any collusion, or otherwise taken any action which is in restraint of free competitive bidding in connection with any bid or contract, that the prequalified bidder has not been convicted of violating *N.C.G.S. § 133-24* within the last three years, and that the prequalified bidder intends to do the work with its own bona fide employees or subcontractors and will not bid for the benefit of another contractor.

By submitting this non-collusion, debarment and gift ban certification, the prequalified bidder is attesting his status under penalty of perjury under the laws of the United States in accordance with the Debarment Certification attached, provided that the Debarment Certification also includes any required statements concerning exceptions that are applicable.

N.C.G.S. § 133-32 and Executive Order 24 prohibit the offer to, or acceptance by, any State Employee of any gift from anyone with a contract with the State, or from any person seeking to do business with the State. By execution of any response in this procurement, you attest, for your entire organization and its employees or agents, that you are not aware that any such gift has been offered, accepted, or promised by any employees of your organization.

SIGNATURE OF PREQUALIFIED BIDDER

Name of Prequalified Bidder _____
Print or type Individual Name

Address as prequalified

Signature of Prequalified Bidder, Individually

Print or type Signer's Name

Signature of Witness

Print or type Signer's name

DEBARMENT CERTIFICATION

Conditions for certification:

1. The prequalified bidder shall provide immediate written notice to the Department if at any time the bidder learns that his certification was erroneous when he submitted his debarment certification or explanation that is file with the Department, or has become erroneous because of changed circumstances.
2. The terms *covered transaction, debarred, suspended, ineligible, lower tier covered transaction, participant, person, primary covered transaction, principal, proposal, and voluntarily excluded*, as used in this provision, have the meanings set out in the Definitions and Coverage sections of the rules implementing Executive Order 12549. A copy of the Federal Rules requiring this certification and detailing the definitions and coverages may be obtained from the Contract Officer of the Department.
3. The prequalified bidder agrees by submitting this form, that he will not knowingly enter into any lower tier covered transaction with a person who is debarred, suspended, declared ineligible, or voluntarily excluded from participation in NCDOT contracts, unless authorized by the Department.
4. For Federal Aid projects, the prequalified bidder further agrees that by submitting this form he will include the Federal-Aid Provision titled *Required Contract Provisions Federal-Aid Construction Contract (Form FHWA PR 1273)* provided by the Department, without subsequent modification, in all lower tier covered transactions.
5. The prequalified bidder may rely upon a certification of a participant in a lower tier covered transaction that he is not debarred, suspended, ineligible, or voluntarily excluded from the covered transaction, unless he knows that the certification is erroneous. The bidder may decide the method and frequency by which he will determine the eligibility of his subcontractors.
6. Nothing contained in the foregoing shall be construed to require establishment of a system of records in order to render in good faith the certification required by this provision. The knowledge and information of a participant is not required to exceed that which is normally possessed by a prudent person in the ordinary course of business dealings.
7. Except as authorized in paragraph 6 herein, the Department may terminate any contract if the bidder knowingly enters into a lower tier covered transaction with a person who is suspended, debarred, ineligible, or voluntarily excluded from participation in this transaction, in addition to other remedies available by the Federal Government.

DEBARMENT CERTIFICATION

The prequalified bidder certifies to the best of his knowledge and belief, that he and his principals:

- a. Are not presently debarred, suspended, proposed for debarment, declared ineligible, or voluntarily excluded from covered transactions by any Federal department or agency;
- b. Have not within a three-year period preceding this proposal been convicted of or had a civil judgment rendered against them for commission of fraud or a criminal offense in connection with obtaining, attempting to obtain, or performing a public (Federal, State or local) transaction or contract under a public transaction; violation of Federal or State antitrust statutes or commission of embezzlement, theft, forgery, bribery, falsification or destruction of records; making false statements; or receiving stolen property;
- c. Are not presently indicted for or otherwise criminally or civilly charged by a governmental entity (Federal, State or local) with commission of any of the offenses enumerated in paragraph b. of this certification; and
- d. Have not within a three-year period preceding this proposal had one or more public transactions (Federal, State or local) terminated for cause or default.
- e. Will submit a revised Debarment Certification immediately if his status changes and will show in his bid proposal an explanation for the change in status.

If the prequalified bidder cannot certify that he is not debarred, he shall provide an explanation with this submittal. An explanation will not necessarily result in denial of participation in a contract.

Failure to submit a non-collusion affidavit and debarment certification will result in the prequalified bidder's bid being considered non-responsive.

Check here if an explanation is attached to this certification.

ITEMIZED PROPOSAL FOR CONTRACT NO. DN12225454							
Line #	Item Number	Sec #	Description	Qty	Units	Unit Cost	Extended Amount
ROADWAY ITEMS							
1	0000915000-N	SP	EMERGENCY MOBILIZATION	6	EA	\$	\$
2	4402000000-E	SP	HIGH VISIBILITY STATIONARY SIGNS	232	SF	\$	\$
3	4407000000-E	SP	HIGH VISIBILITY PORTABLE SIGNS	96	SF	\$	\$
4	4420000000-N	1120	CHANGEABLE MESSAGE SIGNS	1	EA	\$	\$
5	4423000000-N	SP	WORK ZONE DIGITAL SPEED LIMIT SIGNS	5	EA	\$	\$
6	4424000000-N	SP	WORK ZONE PRESENCE LIGHTING	14	EA	\$	\$
7	4432000000-N	SP	HIGH VISIBILITY DRUMS	50	EA	\$	\$
8	4434000000-N	1140	SEQUENTIAL FLASHING WARNING LIGHTS	12	EA	\$	\$
9	4480000000-N	1165	TMA	2	EA	\$	\$
10	4510000000-N	1190	LAW ENFORCEMENT	540	HR	\$	\$
11	4600000000-N	SP	SINGLE LANE CLOSURE	2	EA	\$	\$
12	4600000000-N	SP	CONNECTED LANE CLOSURE SYSTEM	54	EA	\$	\$
13	5080000000-N	SP	LIGHT STANDARD LUMINAIRES, TYPE ***** (RDW, 185W LED)	3	EA	\$	\$
14	5150000000-E	1490	ELECTRICAL DUCT, TYPE **, SIZE***** (TL, 2")	200	LF	\$	\$
15	5150000000-E	1490	ELECTRICAL DUCT, TYPE **, SIZE***** (TL, 3")	200	LF	\$	\$
16	5150000000-E	1490	ELECTRICAL DUCT, TYPE **, SIZE***** (TL, 4")	200	LF	\$	\$
17	5150000000-E	1490	ELECTRICAL DUCT, TYPE **, SIZE***** (TL, 6")	200	LF	\$	\$
18	5150000000-E	1490	ELECTRICAL DUCT, TYPE BD, SIZE ***** (2")	200	LF	\$	\$
19	5150000000-E	1490	ELECTRICAL DUCT, TYPE BD, SIZE ***** (3")	200	LF	\$	\$
20	5150000000-E	1490	ELECTRICAL DUCT, TYPE BD, SIZE ***** (4")	200	LF	\$	\$
21	5150000000-E	1490	ELECTRICAL DUCT, TYPE BD, SIZE ***** (6")	200	LF	\$	\$
22	5170000000-E	1410	** #8 W/G FEEDER CIRCUIT (2)	100	LF	\$	\$
23	5175000000-E	1410	** #6 W/G FEEDER CIRCUIT (2)	100	LF	\$	\$
24	5205000000-E	1410	** #8 W/G FEEDER CIRCUIT IN *****" CONDUIT (2, 1-1/2")	400	LF	\$	\$
25	5210000000-E	1410	** #6 W/G FEEDER CIRCUIT IN *****" CONDUIT (2, 1-1/2")	400	LF	\$	\$
26	5240000000-N	1411	ELECTRICAL JUNCTION BOXES ***** (IG18)	2	EA	\$	\$
27	5240000000-N	1411	ELECTRICAL JUNCTION BOXES ***** (IG30)	2	EA	\$	\$
28	5240000000-N	1411	ELECTRICAL JUNCTION BOXES ***** (IG36)	2	EA	\$	\$

29	5265000000-E	SP	1 #6 THHN/THWN CONDUCTOR	500	LF	\$	\$
30	5265000000-E	SP	1 #8 THHN/THWN CONDUCTOR	500	LF	\$	\$
31	5265000000-E	SP	1 #12 THHN/THWN CONDUCTOR	300	LF	\$	\$
32	5270000000-N	SP	TUNNEL LIGHTING LUMINAIRE	60	EA	\$	\$
33	5270000000-N	SP	TUNNEL LIGHTING BRACKET ASSEMBLY	40	EA	\$	\$
34	5271000000-N	SP	FAULT TROUBLESHOOT AND LOCATE	80	HR	\$	\$
Total Amount Of Bid For Entire Project:							\$

ITEMIZED PROPOSAL FOR CONTRACT NO. DN12225454

Contractor: _____

Address: _____

Phone: _____ Federal ID: _____

Contractor License Number (If Available): _____

Authorized Agent: _____ Title: _____

Signature: _____ Date: _____

Execution of Contract

Contract No: DN12225454

County: Haywood

ACCEPTED BY THE DEPARTMENT

Proposals Engineer

Date

EXECUTION OF CONTRACT AND BONDS
APPROVED AS TO FORM:

Division Engineer

Date